

**SONY®**

***VAIO Slimtop™ LCD  
Computer User Guide***

**PCV-LX900**



## NOTICE

© 2001 Sony Electronics Inc. Reproduction in whole or in part without written permission is prohibited. All rights reserved. This manual and the software described herein, in whole or in part, may not be reproduced, translated, or reduced to any machine-readable form without prior written approval.

SONY ELECTRONICS INC. PROVIDES NO WARRANTY WITH REGARD TO THIS MANUAL, THE SOFTWARE, OR OTHER INFORMATION CONTAINED HEREIN AND HEREBY EXPRESSLY DISCLAIMS ANY IMPLIED WARRANTIES OF MERCHANTABILITY OR FITNESS FOR ANY PARTICULAR PURPOSE WITH REGARD TO THIS MANUAL, THE SOFTWARE, OR SUCH OTHER INFORMATION. IN NO EVENT SHALL SONY ELECTRONICS INC. BE LIABLE FOR ANY INCIDENTAL, CONSEQUENTIAL, OR SPECIAL DAMAGES, WHETHER BASED ON TORT, CONTRACT, OR OTHERWISE, ARISING OUT OF OR IN CONNECTION WITH THIS MANUAL, THE SOFTWARE, OR OTHER INFORMATION CONTAINED HEREIN OR THE USE THEREOF.

Sony Electronics Inc. reserves the right to make any modification to this manual or the information contained herein at any time without notice. The software described herein is governed by the terms of a separate user license agreement.

This product contains software owned by Sony and licensed by third parties. Use of such software is subject to the terms and conditions of license agreements enclosed with this product. Some of the software may not be transported or used outside the United States. Software specifications are subject to change without notice and may not necessarily be identical to current retail versions.

Updates and additions to software may require an additional charge. Subscriptions to online service providers may require a fee and credit card information. Financial services may require prior arrangements with participating financial institutions.

Sony, VAIO, the VAIO logo, VAIO Smart, VAIO Slimtop, ImageStation, DVgate, Media Bar, Handycam, Memory Stick, the Memory Stick logo, MovieShaker, Smart Capture, VisualFlow, PictureGear, PictureToy and i.LINK are trademarks of Sony. Intel and Pentium are trademarks of the Intel Corporation. Microsoft, Windows Me, Windows, and the Windows logo are registered trademarks of Microsoft Corporation. PS/2 is a trademark of IBM Corporation.

All other trademarks are trademarks or registered trademarks of their respective owners.

## Owner's Record

The model number and serial number are located on the back of your Sony VAIO computer. Record the serial number in the space provided here. Refer to the model and serial numbers when you call your Sony Service Center.

Model Number: PCV-LX900

Serial Number: \_\_\_\_\_

## Safety Information and Caution

### CD-RW Laser Diode Properties

|                     |                             |
|---------------------|-----------------------------|
| <b>Laser Output</b> | 1.0mW(Read)<br>35mW (Write) |
| <b>Wave Length</b>  | 777-787nm                   |

- To prevent fire or shock hazard, do not expose your desktop to rain or moisture. To avoid electrical shock, do not open the cabinet. Refer servicing to qualified personnel only.
- Never install modem or telephone wiring during a lightning storm.
- Never install telephone jacks in wet locations unless the jack is specifically designed for wet locations.
- Never touch uninsulated telephone wire or terminals unless the telephone line has been disconnected at the network interface.
- Use caution when installing or modifying telephone lines.
- Avoid using the modem during an electrical storm.
- Do not use the modem or a telephone to report a gas leak in the vicinity of the leak.
- The socket outlet shall be installed near the equipment and shall be easily accessible.



**To change the backup battery, please contact your nearest Sony Service Center.**



**Danger - Visible and invisible laser radiation when open. Avoid direct exposure to beam.**



**Caution - The use of optical instruments with this product will increase eye hazard. As the laser beam used in this product is harmful to the eyes, do not attempt to disassemble the drive cabinet. Refer servicing to qualified personnel only.**



**For CD-RW: Danger - Invisible laser radiation when open. Avoid direct exposure to beam.**



**Caution: For ADSL modem models, to reduce the risk of fire, use only No. 26 AWG or larger telecommunication line cord.**

- Pour prévenir tout risque d'incendie ou d'électrocution, garder cet appareil à l'abri de la pluie et de l'humidité.
- Pour prévenir tout risque d'électrocution, ne pas ouvrir le châssis de cet appareil et ne confier son entretien qu'à une personne qualifiée.
- Ne jamais effectuer l'installation de fil modem ou téléphone durant un orage électrique.

- ❑ Ne jamais effectuer l'installation d'une prise téléphonique dans un endroit mouillé à moins que la prise soit conçue à cet effet.
- ❑ Ne jamais toucher un fil téléphonique à découvert ou un terminal à moins que la ligne téléphonique n'ait été débranché de l'interface réseau.
- ❑ Soyez très prudent lorsque vous installez ou modifiez les lignes téléphoniques.
- ❑ Évitez d'utiliser le modem durant un orage électrique.
- ❑ N'utilisez pas le modem ni le téléphone pour prévenir d'une fuite de gaz vous êtes près de la fuite.
- ❑ L'appareil doit être le plus près possible d'une prise murale pour en faciliter l'accès.



**Pour changer la pile de rechange, veuillez contacter votre centre de service Sony le plus près.**



**Danger : Radiation laser visible et invisible si ouvert. Évitez l'exposition directe au faisceau.**



**Avertissement - L'utilisation d'instruments optiques avec ce produit augmente les risques pour les yeux. Puisque le faisceau laser utilisé dans ce produit est dommageable pour les yeux, ne tentez pas de désassembler le boîtier. Adressez-vous à un agent de service qualifié.**



**Pour les CD-RW : Danger : Radiation laser visible et invisible si ouvert. Évitez l'exposition directe au faisceau.**



**Attention : Pour ADSL modele modem, afin de réduire les risques d'incendie, n'utilisez qu'un cordon de communication NO. 26 AWG ou plus gros.**

For questions regarding your product or for the Sony Service Center nearest you, call 1-888-476-6972 in the United States or 1-800-961-7669 in Canada.

Sony Customer Support can be reached at <http://www.sony.com/pcsupport>

---

## Regulatory Information

### Declaration of Conformity

Trade Name: SONY  
Model No.: PCV-LX900  
Responsible Party: Sony Electronics Inc.  
Address: 1 Sony Drive  
Park Ridge, NJ 07656  
Telephone: 201-930-6972

This phone number is for FCC-related matters only.

This device complies with Part 15 of the FCC rules. Operation is subject to the following two conditions:

- (1) This device may not cause harmful interference, and
- (2) this device must accept any interference received, including interference that may cause undesired operation.

This equipment has been tested and found to comply with the limits for a Class B digital device, pursuant to Part 15 of the Rules. These limits are designed to provide reasonable protection against harmful interference in a residential installation. This equipment generates, uses, and can radiate radio frequency energy and, if not installed and used in accordance with the instructions, may cause harmful interference to radio communications. However, there is no guarantee that interference will not occur in a particular installation. If this equipment does cause harmful interference to radio or television reception, which can be determined by turning the equipment off and on, the user is encouraged to try to correct the interference by one or more of the following measures:

- Reorient or relocate the receiving antenna.
- Increase the separation between the equipment and the receiver.
- Connect the equipment into an outlet on a circuit different from that to which the receiver is connected.
- Consult the dealer or an experienced radio/TV technician for help.

You are cautioned that any changes or modifications not expressly approved in this manual could void your authority to operate this equipment.

Only peripherals (computer input/output devices, terminals, printers, etc.) that comply with FCC Class B limits may be attached to this computer product. Operation with noncompliant peripherals is likely to result in interference to radio and television reception.

All cables used to connect peripherals must be shielded and grounded. Operation with cables, connected to peripherals, that are not shielded and grounded, may result in interference to radio and television reception.

### Declaration of Conformity

Trade Name: SONY  
Model No.: Tablet, model TA-15A

This device complies with Part 15 of the FCC rules and RSS-210 of the IC standards.

Operation is subject to the following two conditions:

- (1) This device may not cause harmful interference, and
- (2) this device must accept any interference received, including interference that may cause undesired operation.

### La déclaration de Conformité

Trade Name: SONY  
Model No.: TABLET, modèle TA-15A

Ce dispositif est conforme à la section 15 des réglementations FCC ainsi qu'au RSS-210 des normes IC.

Son fonctionnement est sujet aux deux conditions suivantes:

- (1) Le dispositif ne peut être à l'origine d'interférences nocives, et
- (2) ce dispositif doit accepter toute réception d'interférences, y compris les interférences qui peuvent entraîner un fonctionnement indésirable.

### FCC Part 68

This equipment complies with Part 68 of the FCC rules. The FCC Ringer Equivalence Number (REN) for this equipment is 0.7. If requested, this information must be provided to the telephone company.

This modem uses the USOC RJ-11 telephone jack.

The REN is used to determine the quantity of devices which may be connected to the telephone line. Excessive RENs on the telephone line may result in the devices not ringing in response to an incoming call. In most, but not all areas, the sum of the RENs should not exceed five (5.0). To be certain of the number of devices that may be connected to the line, as determined by the total RENs, contact the telephone company to determine the maximum REN for the calling area.

If the terminal equipment causes harm to the telephone network, the telephone company will notify you in advance that temporary discontinuance of service may be required. But if advance notice is not practical, the telephone company will notify the customer as soon as possible. Also, you will be advised of your right to file a complaint with the FCC if you believe it is necessary.

The telephone company may make changes in its facilities, equipment, operations or procedures that could affect the operations of the equipment. If this happens, the telephone company will provide advance notice in order for you to make the necessary modifications in order to maintain uninterrupted service.

If trouble is experienced with this modem, for repair or warranty information, please contact 1-888-4SONY-PC, or write to the Sony Customer Information Center, 12451 Gateway Blvd., Fort Myers, FL 33913. If the trouble is causing harm to the telephone network, the telephone company may request that you

---

remove the equipment from the network until the problem is resolved.

Repair of this equipment should be made only by a Sony Service Center or Sony authorized agent. For the Sony Service Center nearest you, call 1-888-4SONYPC (1-888-476-6972).

This equipment cannot be used on public coin service provided by the telephone company. Connection to Party Line Service is subject to state and possible provincial tariffs. (Contact the state or provincial utility service commission, public service commission, or corporation commission for information.)

### ***Telephone Consumer Protection Act of 1991 (United States)***

The Telephone Consumer Protection Act of 1991 makes it unlawful for any person to use a computer or other electronic device to send any message via a telephone facsimile machine unless such message clearly contains, in a margin at the top or bottom of each transmitted page or on the first page of the transmission, the date and time it is sent and an identification of the business, other entity, or individual sending the message, and the telephone number of the sending machine or such business, other entity, or individual.

In order to program this information into your facsimile machine, see your fax software documentation.

### ***Telephone Consumer Guidelines (Canada)***

Please refer to your telephone directory under 'Privacy Issues' and/or 'Terms of Service.' For more detailed information, please contact:

CRTC  
Terrasses de la Chaudière, Tour centrale  
1 promenade du Portage, 5 étage Hull PQ K1A  
0N2.

This Class B digital apparatus complies with Canadian ICES-003.

Cet appareil numérique de la classe B est conforme à la norme NMB-003 du Canada.

## DISPOSAL OF LITHIUM BATTERY

You can return your unwanted lithium batteries to your nearest Sony Service Center or Factory Service Center.

 In some areas the disposal of lithium batteries in household or business trash may be prohibited.

For the Sony Service Center nearest you, call 1-888-476-6972 in the United States or 1-800-961-7669 in Canada.



**Do not handle damaged or leaking lithium batteries.**

**Danger of explosion if battery is incorrectly replaced. Replace only with the same or equivalent type recommended by the manufacturer. Discard used batteries according to the manufacturer's instructions.**

**The battery pack used in this device may present a fire or chemical burn hazard if mistreated. Do not disassemble, heat above 212°F (100°C) or incinerate. Dispose of used battery promptly.**

**Keep away from children.**



**Ne pas manipuler les batteries au lithium qui fuient ou sont endommagées.**

**Une batterie non conforme présente un danger d'explosion. La remplacer seulement par une batterie identique ou de type équivalent recommandé par le fabricant. Évacuer les batteries usées selon les directives du fabricant.**

**La manutention incorrecte du module de batterie de cet appareil présente un risque d'incendie ou de brûlures chimiques. Ne pas démonter, incinérer ou exposer à une température de plus de 100°C. Évacuer promptement la batterie usée.**

**Garder hors de portée des enfants.**



---

### **INDUSTRY CANADA NOTICE**

NOTICE: The Industry Canada label identifies certified equipment. This certification means that the equipment meets certain telecommunications network protective, operational and safety requirements as prescribed in the appropriate Terminal Equipment Technical Requirements document(s). The Department does not guarantee the equipment will operate to the user's satisfaction.

Before installing this equipment, users should ensure that it is permissible to be connected to the facilities of the local telecommunications company. The equipment must also be installed using an acceptable method of connection.

The customer should be aware that compliance with the above conditions may not prevent degradation of service in some situations.

Repairs to certified equipment should be coordinated by a representative designated by the supplier. Equipment malfunctions or any repairs or alterations made by the user to this equipment may give the telecommunications company cause to request that the user disconnect the equipment.

Users should ensure for their own protection that the electrical ground connections of the power utility, telephone lines and internal metallic water pipe system, if present, are connected together. This precaution may be particularly important in rural areas.

CAUTION: Users should not attempt to make such connections themselves, but should contact the appropriate electrical inspection authority, or electrician, as appropriate.

NOTICE: The Ringer Equivalence Number (REN) assigned to each terminal device provides an indication of the maximum number of terminals allowed to be connected to a telephone interface. The termination on an interface may consist of any combination of

devices subject only to the requirement that the sum of the Ringer Equivalence Numbers of all the devices does not exceed 5. The Ringer Equivalence Number for this equipment is 0.7.

### **AVIS DE L'INDUSTRIE CANADA**

AVIS: L'étiquette d'Industrie Canada identifie le matériel homologué.

Cette étiquette certifie que le matériel est conforme aux normes de protection, d'exploitation et de sécurité des réseaux de télécommunications, comme le prescrivent les documents concernant les exigences techniques relatives au matériel terminal. Le Ministère n'assure toutefois pas que le matériel fonctionnera à la satisfaction de l'utilisateur.

Avant d'installer ce matériel, l'utilisateur doit s'assurer qu'il est permis de le raccorder aux installations de l'entreprise locale de télécommunication. Le matériel doit également être installé en suivant une méthode acceptée de raccordement. L'abonné ne doit pas oublier qu'il est possible que la conformité aux conditions énoncées ci-dessus n'empêche pas la dégradation du service dans certaines situations.

Les réparations de matériel homologué doivent être coordonnées par un représentant désigné par le fournisseur. L'entreprise de télécommunications peut demander à l'utilisateur de débrancher un appareil à la suite de réparations ou de modifications effectuées par l'utilisateur ou à cause de mauvais fonctionnement.

Pour sa propre protection, l'utilisateur doit s'assurer que tous les fils de mise à la terre de la source d'énergie électrique, des lignes téléphoniques et des canalisations d'eau métalliques, s'il y en a, sont raccordés ensemble. Cette précaution est particulièrement importante dans les régions rurales.

Avertissement: L'utilisateur ne doit pas tenter de faire ces raccordements lui-même; il doit

avoir recours à un service d'inspection des installations électriques, ou à un électricien, selon le cas.

**AVIS:** L'indice d'équivalence de la sonnerie (IES) assigné à chaque dispositif terminal indique le nombre maximal de terminaux qui peuvent être raccordés à une interface.

La terminaison d'une interface téléphonique peut consister en une combinaison de quelques dispositifs, à la seule condition que la somme d'indices d'équivalence de la sonnerie de tous les dispositifs n'excède pas 5. L'indice d'équivalence de la sonnerie de ce matériel est de 0.7.

# Contents

|   |           |
|---|-----------|
| <b>Welcome.....</b>                                   | <b>13</b> |
| Choosing an Ergonomic Location for Your Computer .... | 13        |
| Front Panel Overview .....                            | 14        |
| Back Panel Overview.....                              | 17        |
| Sony Pen Tablet Overview .....                        | 19        |
| VAIO Pen Overview.....                                | 22        |
| Using Memory Stick® Media.....                        | 31        |
| Using PC Cards.....                                   | 33        |
| <br>  |           |
| <b>VAIO® Action Setup.....</b>                        | <b>37</b> |
| Programmable Power Keys .....                         | 37        |
| Presetting i.LINK® devices.....                       | 39        |
| Changing the Window Design of Sony Software.....      | 40        |
| AutoAlert™ E-mail Notification System .....           | 41        |
| <br>  |           |
| <b>Configuring your VAIO Slimtop™</b>                 |           |
| <b>LCD Computer .....</b>                             | <b>43</b> |
| Hard Disk Drive Partition .....                       | 43        |
| Defragmenting your Hard Disk Drive .....              | 43        |
| i.LINK® (IEEE1394) Compatibility .....                | 44        |
| Enabling Ethernet .....                               | 46        |

|  |            |
|--|------------|
| <b>VAIO® AV Applications.....</b>                              | <b>47</b>  |
| MovieShaker™ .....   | 49         |
| PictureGear™ .....   | 53         |
| OpenMG™ Jukebox 2.0 .....                                      | 55         |
| Smart Capture™ .....   | 62         |
| VisualFlow™ .....  | 73         |
| DVGate™ .....  | 74         |
| <br>   |            |
| <b>System, Application, and<br/>Driver Recovery CD(s).....</b> | <b>77</b>  |
| Using the System Recovery CD(s) .....                          | 77         |
| Using the Application Recovery CD(s) .....                     | 78         |
| Using the Driver Recovery CD.....                              | 79         |
| <br>   |            |
| <b>Using the VAIO Support Agent.....</b>                       | <b>81</b>  |
| Using the Quick Fix Wizard .....                               | 82         |
| Using Common Solutions .....                                   | 83         |
| Using Support Central.....                                     | 84         |
| Software Applications protected<br>by VAIO Support Agent ..... | 88         |
| <br>   |            |
| <b>Troubleshooting .....</b>                                   | <b>89</b>  |
| Topics.....  | 89         |
| Notes on Use .....   | 100        |
| For Answers to Your Software Questions .....                   | 105        |
| Resources .....  | 108        |
| <br>   |            |
| <b>Specifications .....</b>                                    | <b>111</b> |

# Welcome

*Thank you for purchasing your Sony VAIO Slimtop™ LCD computer! Your new computer is a superb blend of high technology and easy-to-use functionality. This User Guide contains information about the applications included with your system, contact information for software vendors, and the specifications for your computer.*

## Choosing an Ergonomic Location for Your Computer

---

Before you get started, find the best location for your new computer. Here are some things to consider when planning your workspace:

- ❑ **Stable work surface** — Use a stable work surface large enough to support the computer and other peripheral equipment.
- ❑ **Ventilation** — Leave at least eight inches of space on the left and back sides of your computer to enable proper ventilation.
- ❑ **Placement of the keyboard, mouse, and other input devices** — Place your keyboard, mouse, and other input devices so that your arms and hands are in a relaxed, comfortable position. The keyboard should be directly in front of you. Adjust the level of the keyboard so that your lower arms are parallel to the floor. Keep your wrists in a relaxed position when you are using the keyboard—not angled up or down. Use the palmrest only briefly, for resting. While typing, never use the palmrest or rest your hands on the table. Position the mouse at the same level as the keyboard. Hold the mouse with a relaxed hand, and use your whole arm to move it. Take breaks during sessions with your computer. Excessive use of the mouse or a joystick may strain muscles or tendons.
- ❑ **Furniture and posture** — Sit in a chair with good back support and armrests. Adjust the level of the chair so your feet are flat on the floor. A footrest may make you more comfortable. Sit with relaxed, upright posture—avoid slouching forward or leaning far backward.
- ❑ **Viewing angle of the display** — Position the display 18 to 26 inches directly in front of you, with the top of the screen at or a little below eye

level. Use the display's tilting feature to find the best position. You can reduce eye strain and muscle fatigue by placing the display in the proper position.

- ❑ **Lighting** — Choose a location where windows and lights do not create glare and reflection on the display. Use indirect lighting to avoid bright spots on the display. You can also purchase accessories for your display that help reduce glare. Proper lighting adds to your comfort and work effectiveness.

## Front Panel Overview

---

The front panel of your VAIO Slimtop™ Computer allows for access to the CD-RW drive. It also contains Universal Serial Bus (USB) and i.LINK® ports to connect USB devices, digital equipment, or other components.

 i.LINK is a trademark of Sony used only to designate that a product contains an IEEE1394 connection. The i.LINK connection may vary, depending on the software applications, operating system and i.LINK-compatible devices. All products with an i.LINK connection may not communicate with each other.

Please refer to the documentation that came with your i.LINK-compatible device for information on operating conditions and proper connection. Before connecting i.LINK-compatible PC peripherals to your system, such as a CD-RW or Hard Disk Drive, confirm their operating system compatibility and required operating conditions.

**Locating Controls and Ports**

**Front Panel**

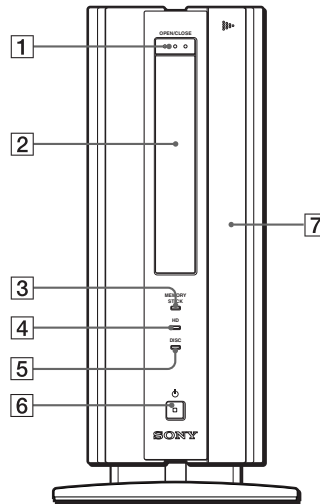

- 
- 1** **CD-RW eject button**  
Ejects a disc from the CD-RW drive.
- 
- 2** **CD-RW drive**  
Reads data from a CD and writes data to a CD-R or CD-RW disc.
- 
- 3** **Memory Stick® access indicator light**  
Lights in amber while reading and writing data from and to a Memory Stick media.
- 
- 4** **Hard disk drive access indicator light**  
Lights in amber while reading and writing data from and to the hard disk.
- 
- 5** **CD-RW drive access indicator light**  
Lights in amber while reading and writing data from and to a CD-R or CD-RW disc.
- 
- 6** **Power switch and indicator light**  
Turns on/off the computer and the display.  
The indicator light is green while the power is on and amber when the computer is in standby mode.
- 
- 7** **Front panel cover**  
A Sliding panel that covers the PC card slot, Memory Stick slot, and connectors.
-

Front Panel (cont.)

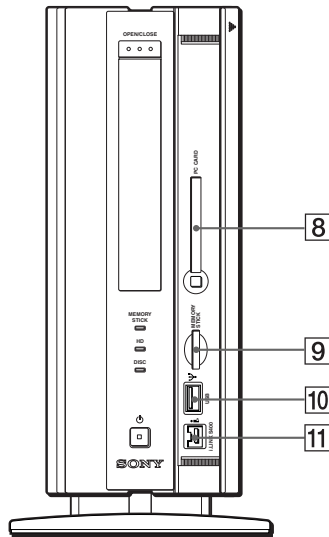

**8** **PC Card slot**

A PC card (also called a PCMCIA card) can be installed in this slot. PC cards enable you to add functionality to your system.

**9** ** MEMORY STICK® media slot**

Insert a Sony MEMORY STICK media into this slot.

**10** ** Universal Serial Bus (USB) port**

Connection for a USB device.

**11** ** i.LINK 4-pin port (IEEE1394)**

Connection for an i.LINK-compatible digital device, such as a Sony Digital Handycam® Camcorder.



## Back Panel Overview

The back panel of your computer contains the ports for supplied and optional accessories. The icons on the back panel help locate and identify the ports on your computer.

### Locating Ports

#### Back Panel

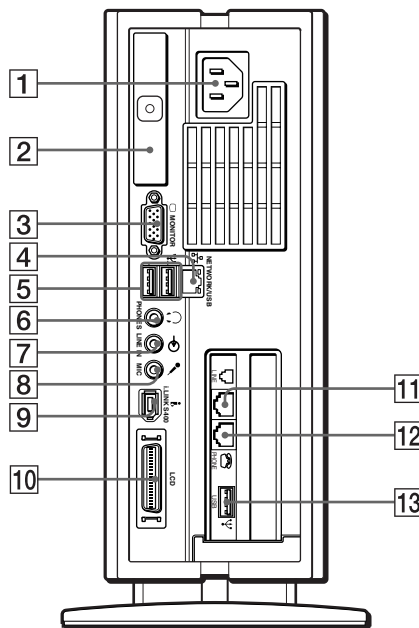

- 1 AC Input port**  
Connection for the supplied power cord.
- 2 T-Lever**  
A handle that is used to remove the unit's cover.
- 3 Monitor port**  
Connection for a standard CRT display.

- 
- 4**    **ETHERNET port**  
10Base-T/100Base-TX Fast Ethernet interface.  
(The port marked with  (Network) is for LAN connections only.)
- 
- 5**    **Ψ Universal Serial Bus (USB) ports (2)**  
Connections for USB devices. Two USB ports are located on the back panel and one USB port is located on the modem card (See #13).
- 
- 6**    **🎧 Headphones jack**  
Connection for optional headphones or computer speakers.
- 
- 7**    **Line In jack**  
Connection for an optional audio device.
- 
- 8**    **🎤 Microphone jack**  
Connection for an optional microphone.
- 
- 9**    **📷 i.LINK® 6-pin port (IEEE1394)**  
Connection for a compatible digital device such as a Sony Digital Handycam® Camcorder.
- 
- 10**    **LCD display (monitor) port**  
Connection for the supplied Sony Pen Tablet.  
Note: Do not connect any other display to this port.
- 
- 11**    **Line jack**  
Connection for the supplied modem cable to the wall jack.
- 
- 12**    **Telephone cable jack**  
Connection for the phone cable to the computer.
- 
- 13**    **Ψ Universal Serial Bus (USB) port**  
Connection for a USB device.
- 

 i.LINK is a trademark of Sony used only to designate that a product contains an IEEE1394 connection. The i.LINK connection may vary, depending on the software applications, operating system, and i.LINK-compatible devices. All products with an i.LINK connection may not communicate with each other.

Please refer to the documentation that came with your i.LINK-compatible device for information on operating conditions and proper connection. Before connecting i.LINK-compatible PC peripherals to your system, such as a CD-RW or Hard Disk Drive, confirm their operating system compatibility and required operating conditions.

## Sony Pen Tablet Overview

Your VAIO Slimtop™ Computer is supplied with a Sony Pen Tablet display (TA-15A), a VAIO Pen and accessories.

The Sony Pen Tablet is a graphic interface that provides a pressure-sensitive work area. The VAIO Pen is a cordless input device that controls the movement of the cursor on the surface of the tablet screen. The pen stand, pen tip replacements, and pen tip removing tool help you protect and care for your VAIO Pen.



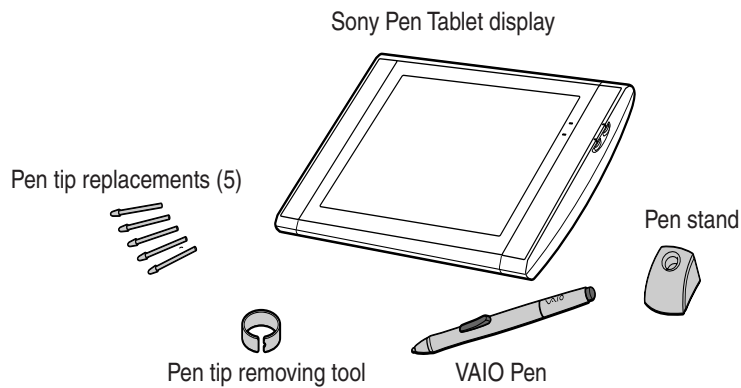

 Place the VAIO Pen in the supplied pen stand when it is not in use, to maintain the sensitivity of the pen tip and to avoid interference with other pointing devices, such as your mouse.

### Sony Pen Tablet and accessories

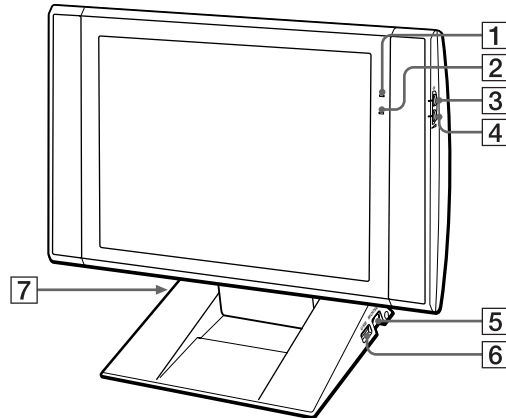

*Sony Pen Tablet Display (Shown in an upright position)*



- 
- 1**  **Power indicator light**  
Light is green while the power is on. When the computer enters standby mode, this indicator light turns amber.
- 
- 2**  **Information LED light**  
Light turns red to alert the user to activities, such as the arrival of e-mail. See “AutoAlert E-mail Notification System.”
- 
- 3**  **Brightness control**  
Adjusts the brightness of the screen.
- 
- 4**  **Volume control**  
Adjusts the volume of the integrated speakers on the LCD display.
- 
- 5** **PS/2® mouse port**  
Connection for a mouse.
- 
- 6**  **Universal Serial Bus (USB) port**  
Connection for a USB device.
- 
- 7** **PS/2® keyboard port**  
Connection for a VAIO Convertible Keyboard.
-

### **Adjusting the Sony Pen Tablet display (TA-15A)**

- 1 Holding both sides of the display, push the display panel out and up.

#### **Adjusting the height and viewing angle of the display**

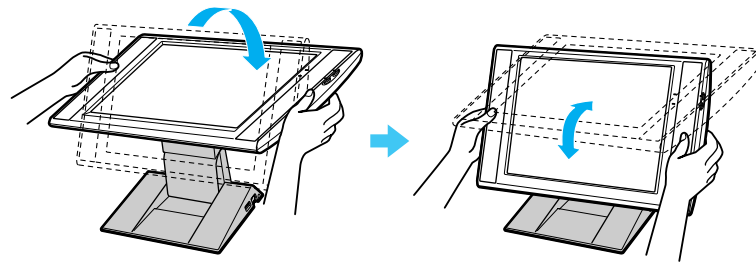

- 2 Set the display height so that it covers the keyboard, and adjust the screen for a viewing angle that allows you to work with the tablet and VAIO pen comfortably.

#### **Adjusting viewing angle**

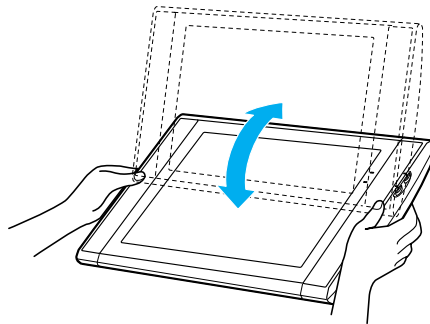

**The Sony Pen Tablet operates with radio-frequency energy. This may cause interference with radio and television reception, if the display is not installed and used correctly. If your tablet is interfering in this manner, move the equipment away from the radio or television.**

## VAIO Pen Overview

The VAIO Pen controls the cursor movements on the Sony Pen Tablet screen. Hold the pen in the same manner as a pen or pencil, making sure that the rocker switch on the side is within reach of your thumb or forefinger, but cannot be accidentally pressed while drawing or writing.

The VAIO Pen is activated when it is held within close proximity to the pen tablet screen. You can position the cursor on the pen tablet screen or use the rocker switch, without touching the pen tip to the tablet surface. The upper/lower switch positions and eraser can be programmed to perform different functions. See the Sony Pen Tablet online help for more information on VAIO Pen settings.

### VAIO Pen

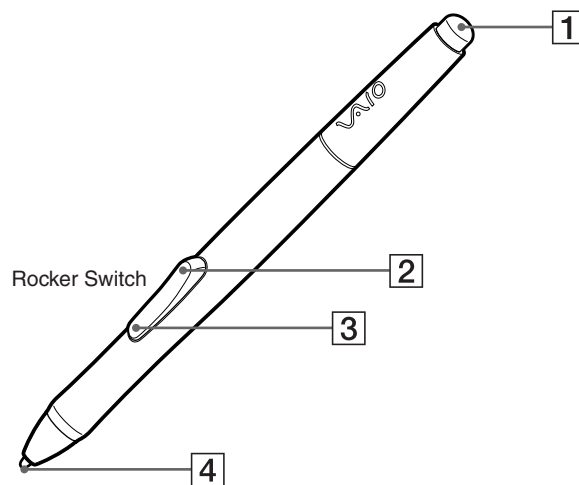

- |          |  |
|----------|--|
| <b>1</b> | <b>Eraser</b><br>Delete unwanted portions of your work, depending on the application in use.   |
| <b>2</b> | <b>Upper switch position</b><br>The upper side of the rocker switch is set to deliver a double left click by default.  |
| <b>3</b> | <b>Lower switch position</b><br>The lower side of the rocker switch is set to deliver a right click by default.  |
| <b>4</b> | <b>Pen tip</b><br>You can use the pen tip to draw or write. Tapping the pen tip against the tablet screen delivers a click in the same manner as the left button on a mouse. |

Your VAIO Pen, eraser, and the upper/lower switch positions are programmable.

By default, the basic functions performed by the VAIO Pen are:

- ❑ **Pointing** — Place the tip of the pen anywhere on the pen tablet screen and the screen cursor will automatically correspond to that point.
- ❑ **Clicking** — Tap the pen tablet screen once with the tip of the pen, or press the pen tip against the screen with enough pressure to register a single click.
- ❑ **Double clicking** — Quickly tap the pen tablet screen twice in the same place with the tip of the pen. You can also register a double click by pressing the upper switch position of the pen's rocker switch.
- ❑ **Dragging** — Point to and select an object by pressing the pen to the pen tablet screen. Slide the pen tip across the tablet to move the object to the desired location. To select text, point to the beginning of the text, and then drag the pen across the tablet until all of the desired text is highlighted.

#### *To replace the Pen tip*

Your VAIO Pen is supplied with pen tip replacements. The pen tip wears with normal use and must be replaced when the tip becomes too short or develops a flat point. Follow these steps to replace the pen tip:

- 1 Clasp the worn pen tip with the pen tip removing tool and pull it straight out of the VAIO Pen barrel.
- 2 Slide the flat end of a new pen tip straight into the barrel, pushing the tip firmly until it stops.

#### *Replacing the pen tip*

Step One

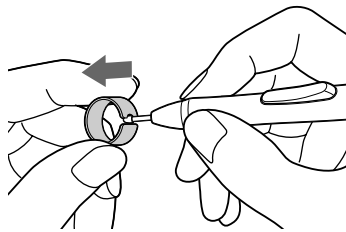

Step Two

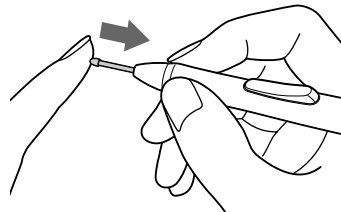

## Configuring the VAIO Pen

### To change the pen tip, eraser and upper/lower switch functions

- 1 From the Start menu, point to Settings, and then click on Control Panel.
- 2 Click on Sony Tablet. The Sony Tablet Properties window appears.
- 3 From the Tool Buttons tab, click the drop-down list for the pen function you wish to change. Select the desired function for the pen tip, eraser, or the upper/lower switch positions.

### Sony Tablet Properties main window

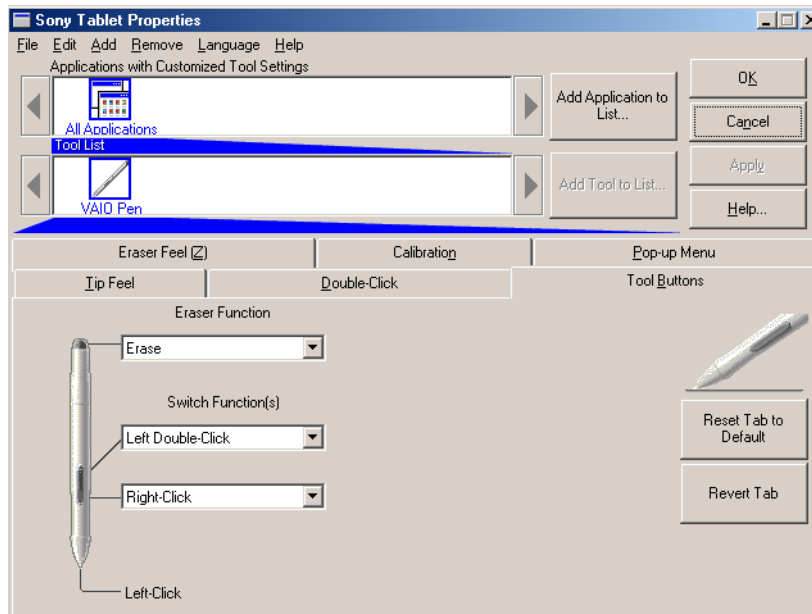

| <b>Function</b>          | <b>Description</b>                                 |
|--------------------------|--|
| <b>Left-Click</b>        | Single click of the left mouse button.             |
| <b>Left Double-Click</b> | Double-click of the left mouse button.             |
| <b>Right-Click</b>       | Single click of the right mouse button.            |
| <b>Middle-Click</b>      | Clicking the center wheel button of a wheel mouse. |
| <b>Left-Click Lock</b>   | Holds down the left mouse button.                  |



| <i>Function</i>      | <i>Description</i>                                       |
|----------------------|--|
| <b>Pressure Hold</b> | Keeps the pen tip pressure constant.                     |
| <b>Pop-up Menu</b>   | Displays a pop-up menu at the cursor position.           |
| <b>Erase</b>         | Operates as an eraser.                                   |
| <b>Keystroke</b>     | Performs a programmed keystroke.                         |
| <b>Modifier</b>      | Operates as the Shift, Alt, or Ctrl key (as programmed). |
| <b>Ignored</b>       | No function is assigned.                                 |

 The Left-Click function is assigned by default to the pen tip. Before you change the pen tip setting to perform a different function, assign the Left-Click function to another switch. Sony suggests assigning the Left-Click function to the pen tip when using the pen with drawing applications.

 You can reset your VAIO Pen functions to the factory default settings by using the “Reset Tab to Default” button. You can revert to a previously saved setting by using the “Revert tab.”

### *To calibrate your pen to your tablet screen*

- 1 From the Sony Tablet Properties screen, click on the Calibration tab.
- 2 Click on the “Calibrate...” button. Follow the onscreen instructions to align your pen’s cursor positioning to the tablet screen coordinates.

### *Calibration Tab*

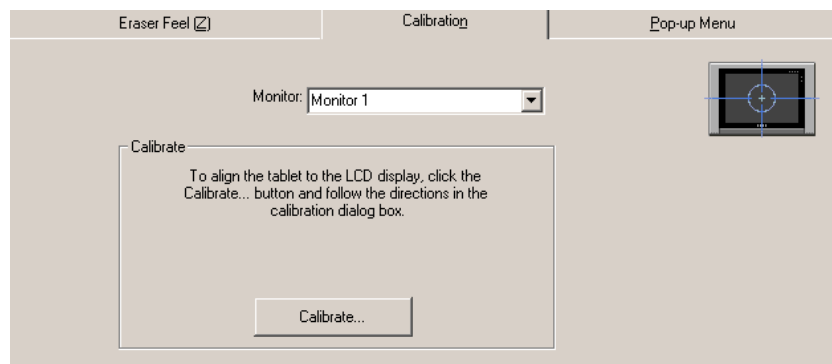

- 3 Click Apply. The onscreen cursor location is adjusted to correspond to the pen tip.

#### *To adjust the pen tip pressure and feel*

- 1 From the Sony Tablet Properties screen, click on the Tip Feel tab.
- 2 Test the pen tip feel by drawing lines in the “Draw here” Test area. The lines are drawn with the current pen pressure settings.
- 3 Check the pen’s clicking pressure by tapping on the Click button in the Test area. If you tap more forcefully than the pen’s current settings, the Click button changes color.

#### *Tip Feel Tab*

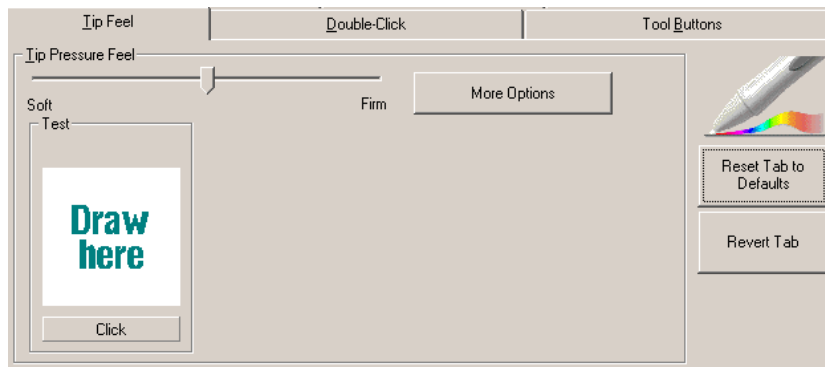

- 4 Adjust the pen tip pressure feel by sliding the measurement to a desired level. The pressure settings range from Soft, which requires light pressure, to Firm, which requires more forceful pressure.
- 5 Click on the More Options button if you wish to make a more in-depth adjustment to the pen tip pressure feel.
- 6 Click Apply. The new tip pressure feel settings are applied to the pen.

 You can reset your pen tip pressure feel to the factory default settings by using the “Reset Tab to Default” button. You can revert to previously saved pen tip pressure feel settings by using the “Revert tab.”



### To adjust the pen's double-click speed and distance

- 1 From the Sony Tablet Properties screen, click on the Double-Click tab.
- 2 To allow the Sony Tablet software to automatically adjust the double-click speed and distance, place a check mark in the box located next to Double-Click Assist.

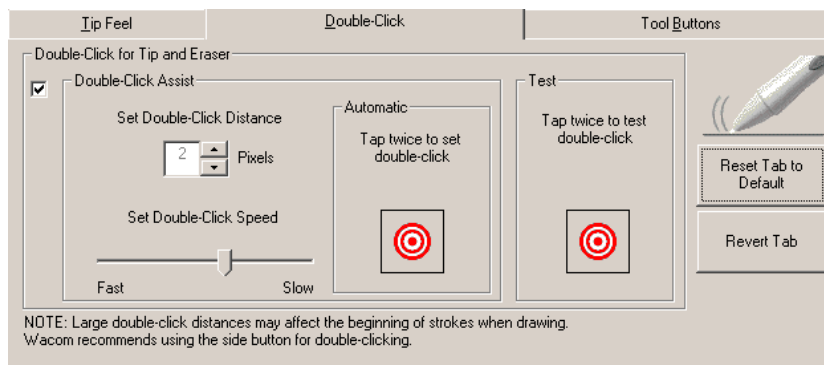
### Double-click Tab



 You can disable the Double-Click Assist for specific applications. When Double-Click Assist is disabled, you can only double-click by using the upper switch position. For more information about disabling the settings for specific applications, see “Customizing the pen settings for specific software applications.”

- 3 Automatically set both the double-click speed and distance by tapping twice on the  in the “Automatic” area.
- 4 You can manually change “Set Double-Click Distance” to a distance between 1-25 pixels by clicking on the up/down arrows. You can also manually change “Set Double-Click Speed” by moving the measurement to a desired speed.
- 5 You may test your double-click speed and distance settings by tapping twice on  in the Test area. If your tapping matches the current double-click settings, the button icon changes  to indicate a successful test. If the icon does not change after several tests, review your double-click speed and distance settings.

- 6 Click Apply. The new double-click speed and distance settings are applied to the pen.

 You can reset your double-click speed and distance to the factory default settings by using the “Reset Tab to Default” button. You can revert to previously saved double-click settings by using the “Revert tab.”

### *To adjust the eraser pressure and feel*

- 1 From the Sony Table Properties screen, click on the Eraser Feel tab.
- 2 To check the current erase pressure feel, erase the phrase “Erase this text” in the Test area. The text disappears when you are erasing more forcefully than the current setting.
- 3 Test the eraser feel by erasing in the “Erase here” Test area. The erased area changes color when you are erasing more forcefully than the current setting.

### *Eraser Feel Tab*

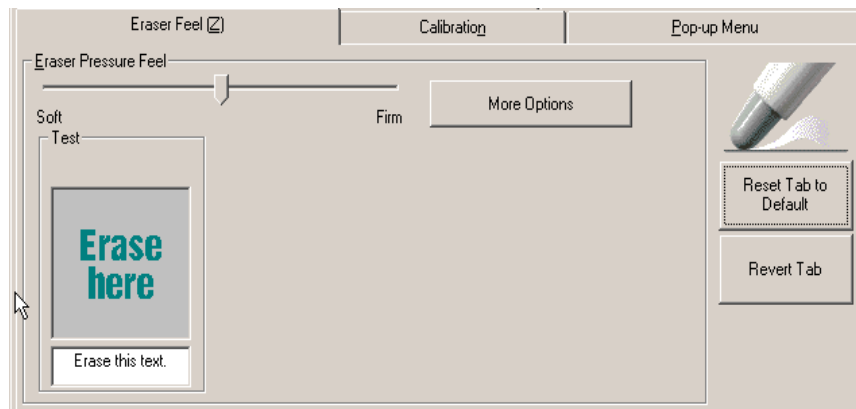

- 4 Adjust the eraser pressure feel by sliding the measurement to a desired position. The pressure settings range from Soft, which requires light pressure, to Firm, which requires more forceful pressure.
- 5 Click on the More Options button if you wish to make a more in-depth adjustment to the eraser pressure feel.

- 6 Click Apply. The new eraser pressure feel settings are applied to the pen.

 You can reset your eraser pressure feel to the factory default settings by using the “Reset Tab to Default” button. You can revert to previously saved eraser pressure feel levels by using the “Revert tab.”

### Configuring the Pop-up menu

The Sony Tablet Properties window has a Pop-up Menu tab that can be used to configure onscreen pop-up menus. (The Pop-up Menu function can be assigned to the VAIO Pen.) If you press a pen switch position that is assigned to the Pop-up Menu function, a small pop-up menu appears at the onscreen cursor position. You can execute a predetermined operation by selecting settings from the pop-up menu. For more information on configuring Pop-up menus, see the Sony Tablet online help.

#### Pop-up Menu Tab

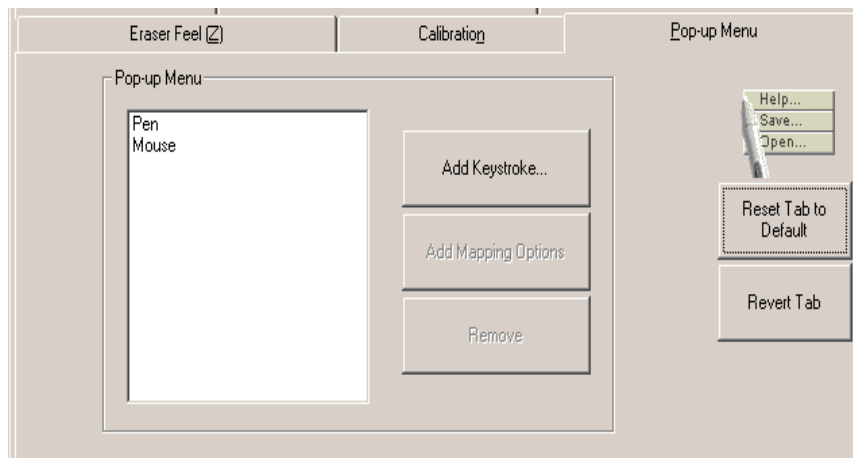

 You can reset the Pop-up menu function to the factory default settings by using the “Reset Tab to Default” button. You can revert to previously saved Pop-up menu settings by using the “Revert Tab.”

### ***Customizing the pen settings for specific software applications***

You can customize your pen settings for a specific software application. When you use different software, the associated pen settings are applied automatically, enabling you to take full advantage of each software application's features.

#### ***To add an application to the custom settings list***

- 1 From the Sony Tablet Properties window, click on the “Add Application to List...” button. The “Add Application for Custom Settings” dialog box appears.
- 2 Click OK.

#### ***To create custom settings for an application***

- 1 Select a software application from the “Applications with Customized Tool Settings” list.
- 2 Customize the pen settings for each software application according to the software's features. The settings apply only to the selected application.

 If you have pen settings that you want to apply to all software applications, select “All Other Apps” before changing the setting.

- 3 Click Apply.

#### ***To remove an application from the custom settings list***

- 1 Click on the Remove menu, click on “Custom Settings for Application”, and then select the application(s) to be removed.
- 2 Click OK.

 For more information on customizing your VAIO Pen settings, see the Sony Tablet online help.

## Using Memory Stick® Media

Your VAIO Slimtop™ computer is designed to support the new Memory Stick storage media. The Memory Stick media is a compact, portable, and versatile device designed for exchanging and sharing digital data with compatible products.

You can use VAIO Action Setup to preset your computer to automatically launch an application when you insert a Memory Stick media.

### Inserting the Memory Stick Media

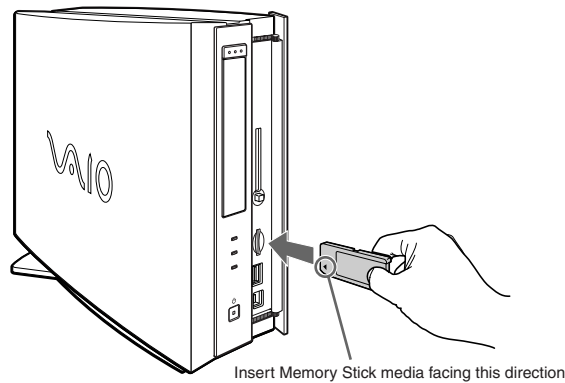

 When you insert a Memory Stick media, your computer automatically launches the VisualFlow™ browser to allow you to view the contents of the media.

### To protect data on Memory Stick media from accidental changes

Memory Stick media contains a write-protect tab. The write-protect tab prevents accidental changes to information recorded on your Memory Stick media. When you slide the write-protect tab to the LOCK position, your Memory Stick media is write-protected. This means that you cannot delete, copy, or save information on the media. When you slide the tab to the un-LOCK position, you can write to or modify your Memory Stick media's contents.

**Locking the Memory Stick Media**

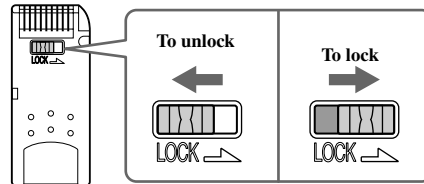

***To change the way the computer responds when a Memory Stick media is inserted***

You can change the way your system responds by changing the options on the Memory Stick tab in the PPK Setup utility.



## Using PC Cards

Your computer has a card bus PC card slot that supports a Type I or Type II PC card.

 You do not need to shut down your computer when inserting a PC card.

### To insert a PC card

- 1 Slide front panel cover in the direction of arrow as shown in picture, to open it.

### Opening the front panel



- 2 Insert the PC card into the PC card slot until it clicks into position.

### Inserting a PC card

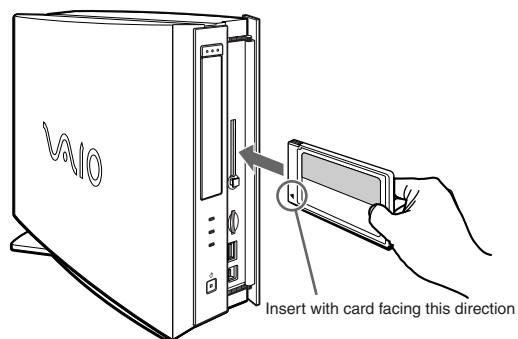

 When the PC card is inserted correctly, the eject button pops out. If the card does not insert easily, make sure the card is not being inserted upside-down or backwards. Carefully reinsert the card into the slot, but do not force it in.

See the manual that came with the PC card for details on using it.

If the eject button is extended, fold the button down onto the computer before closing the front panel.

### *To eject a PC card*

 If you eject the PC card incorrectly, the system may not work correctly.

### *Ejecting a PC card*

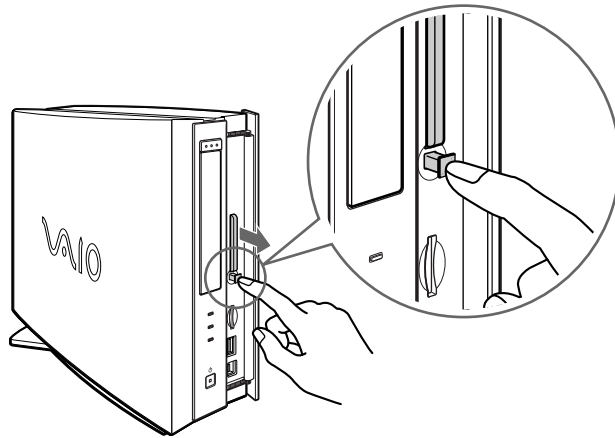

- 1 From the Start menu, point to Settings, point to Control Panel, and then click on the PC card icon.
- 2 Click the name of the card that you want to eject, and then click Stop.
- 3 When the message “You may safely remove this device” appears, click OK.

- 4 Push the PC card eject button on the front panel of the system unit. You may need to extend the eject button out from the computer before you can eject the card.
- 5 When the PC card ejects from the PC card slot, remove it by holding the edges and pulling it out carefully.



## VAIO® Action Setup

VAIO Action Setup manages the settings for your computer's Programmable Power Keys (PPK), internal timer, i.LINK® interface, and Memory Stick® media. For more information on changing these settings using VAIO Action Setup, see the online VAIO Action Setup Help.

### *To access VAIO Action Setup Help:*

- 1 Click Start, point to Programs, and then point to VAIO Action Setup.
- 2 Click VAIO Action Setup Help.

## **Programmable Power Keys**

Your Sony computer is equipped with technology that allows you to access your favorite applications quickly. Each Programmable Power Key (PPK) on your VAIO Convertible keyboard is programmed to launch a preset application with a single press of the key. If you wish, you can use VAIO Action Setup to change the PPK functions.



The Programmable Power Keys are located at the right side of your keyboard, and are numbered P1 through P4. The keys work even when the computer is turned off. Pressing one of the PPK buttons turns on the computer and launches the preset application.

The four Programmable Power Keys preprogrammed to perform the following functions.

| <b>Key</b>    | <b>Function</b>                                      |
|---------------|--|
| P1 (MAIL)     | Starts Microsoft® Outlook® Express.                  |
| P2 (INTERNET) | Starts Microsoft® Internet Explorer for Windows Me™. |
| P3 (PICTURE)  | Starts Sony's PictureGear™.                          |
| P4 (HELP)     | Starts VAIO® Demo/Help.                              |

### **To change the settings of the PPKs**

- 1 From the Start menu, point to Programs, point to VAIO Action Setup, and then click VAIO Action Setup.

 You can also double-click  in the Windows taskbar to open VAIO Action Setup.

- 2 Click the PPK you want to change.
- 3 From the Select Application dialog box, click the option for the desired function. The corresponding applications appear in the list box on the right.

 You may also use the drag-and-drop feature to place any application into the list box.

- 4 The Confirmation Application Name window appears and displays the application you have selected. Click Next.
- 5 The Input Application Name window appears. You can type a new name and description, if desired. Click Finish.

### **Internal Timer**

The VAIO Action Setup software allows you to set your computer's internal timer to launch certain applications automatically.

 Some software applications take longer than others to launch. It is advisable to confirm in advance the amount of time your selected application takes to start.

## Presetting i.LINK® devices

---

You can preset your i.LINK-equipped devices to perform desired functions, such as automatically starting DVgate™ software or connecting two VAIO® computers.

 i.LINK is a trademark of Sony used only to designate that a product contains an IEEE1394 connection. The i.LINK connection may vary, depending on the software applications, operating system and i.LINK-compatible devices. All products with an i.LINK connection may not communicate with each other.

Please refer to the documentation that came with your i.LINK-compatible device for information on operating conditions and proper connection. Before connecting i.LINK-compatible PC peripherals to your system, such as a CD-RW or Hard Disk Drive, confirm their operating system compatibility and required operating conditions.

### *To preset your i.LINK device to perform a desired function*

- 1 From the Start menu, point to Programs, point to VAIO Action Setup, and then click on VAIO Action Setup.  
The VAIO Action Setup windows appears.
- 2 Click i.LINK.
- 3 Click the Advanced Setting tab.
- 4 Click the Enable i.LINK launcher function checkbox and click Apply.
- 5 Connect the device to your computer with your i.LINK cable.
- 6 Turn on the device.  
The VAIO Action Setup dialog box appears.
- 7 Click OK.
- 8 To modify the device name, click the current device name in the list box and click Modify device name.
- 9 Type the desired name and click Apply.
- 10 To assign an application, click Modify.  
The Select Application dialog box appears.
- 11 Select the desired application and click Next.

- 12 Click Next to confirm the application name.

The Input Application Name dialog box appears. You may change the name and description of the application you want to launch.

- 13 Click Finish to complete this step.

The next time the device is connected and turned on, the assigned application will launch automatically.

---

## ***Changing the Window Design of Sony Software***

---

### ***To change the window design***

- 1 From the Start menu, point to Settings, and then click on Control Panel.
- 2 Click UI Design Selector.
- 3 Click << or >> and select the desired design.
- 4 Click Apply.
- 5 The “UI Design Selector” window design changes. The window design for your Sony software will match the “UI Design Selector” window.
- 6 To try another selection, click << or >> and then click OK.
- 7 The UI Design Selector closes and the Sony software window design displays.

 You may use the feature with UI Design Selector-compatible software only.



## **AutoAlert™ E-mail Notification System**

---

The VAIO® Action Setup utility enables you to program your computer to notify you when new mail arrives in your e-mail mailbox. The  Information LED turns red to indicate that new e-mail has arrived. For the AutoAlert E-mail Notification System to work, you must use Microsoft® Outlook® Express as your default e-mail software, and have an Internet Service Provider (ISP) with dial-up capabilities set up.

As an alternative, you can program your AutoAlert E-mail Notification System to have the Information LED indicate when it has successfully completed the task of dialing up and connecting to receive e-mail. In this case, the Information LED lights to indicate that your e-mail account has been successfully accessed, regardless of whether or not you have e-mail. This feature is supported by the preconfigured e-mail applications listed in the VAIO Action Setup utility.

 The e-mail software you choose to use with the PPK must be set as your default e-mail software.

### **AutoAlert E-mail Notification System Software Restrictions**

#### ***If you use software that requires use of a phone line***

- The computer may not be able to disconnect the phone line due to communication and server conditions.
- Monitor the status of the software when running the AutoAlert E-mail Notification System, and manually disconnect the phone line if you notice a malfunction. When using the timer to start the software, set the computer to shut down or enter system standby mode after a certain length of time. This allows the computer to disconnect the phone line if the computer does not disconnect the line normally.

#### ***If you are using the timer to download e-mail automatically***

- Set up your e-mail software to redial automatically if it does not connect the first time.
- Set up your e-mail software to disconnect the phone line automatically when all mail has been downloaded.

***If you are using Microsoft® Outlook® Express***

When using the AutoAlert E-mail Notification System with Microsoft Outlook Express, select the “Dial automatically” setting in your Microsoft Outlook Express software. To adjust this setting:

- 1 Start Outlook Express.
- 2 Click Tools, and then select Options.
- 3 From the drop-down box, select “Connect even when working offline.”
- 4 Click OK.
- 5 Click Send/Receive.

A dial-up connection window appears. Select the desired ISP, and then click Connect Automatically.

# Configuring your VAIO Slimtop™ LCD Computer

## Hard Disk Drive Partition

---

In order to improve the performance of the DVgate™ software, the hard disk drive on your computer has been formatted with two partitions, C and D. The DVgate™ software saves files to the D partition. This prevents large video captures from consuming the available space on your C partition. To maintain optimum DVgate™ performance, you should defragment your D partition regularly.

## Defragmenting your Hard Disk Drive

---

If you encounter frame dropping while recording digital video onto your hard disk drive, defragmentation may be necessary.

### *To defragment your hard disk drive*

- 1 Deactivate your screen saver, if applicable.
- 2 From the Start menu, point to Programs, point to Accessories, point to System Tools, and then click on Disk Defragmenter.
- 3 Run Disk Defragmenter.

 It may take more than a couple of hours to complete defragmentation, depending on the data capacity and utilization of your computer's hard disk drive(s).

## ***i.LINK® (IEEE1394) Compatibility***

Your VAIO computer includes a 4-pin i.LINK port on the front of the system and a 6-pin i.LINK port on the back of the system.

 i.LINK is a trademark of Sony used only to designate that a product contains an IEEE1394 connection. The i.LINK connection may vary, depending on the software applications, operating system and i.LINK-compatible devices. All products with an i.LINK connection may not communicate with each other.

Please refer to the documentation that came with your i.LINK-compatible device for information on operating conditions and proper connection. Before connecting i.LINK-compatible PC peripherals to your system, such as a CD-RW or Hard Disk Drive, confirm their operating system compatibility and required operating conditions.

A 4-pin i.LINK port cannot supply power to a connected device.

A 6-pin i.LINK port can:

- supply power from the computer to the connected device if the device is equipped with a 6-pin connector, and
- supply 10V to 12V.



**The total power supplied by the 6-pin i.LINK port cannot exceed 6 watts.**

The following Sony i.LINK 400 Mbps cables are available and recommended for use with your computer: VMC-IL4415, VMC-IL4435, VMC-IL4615, VMC-IL4635, VMC-IL6615, and VMC-IL6635. Sony computer supplies, accessories, and peripherals can be purchased from your local retailer or by contacting Sony VAIO® Direct Web site (<http://vaio.sonymstyle.com>), or by calling 1-888-315-7669 (toll free).

**To connect an i.LINK (IEEE1394) device**

- Use the  symbol to locate the i.LINK port. Plug the i.LINK cable into this port.

**Connecting an i.LINK (IEEE1394) device**

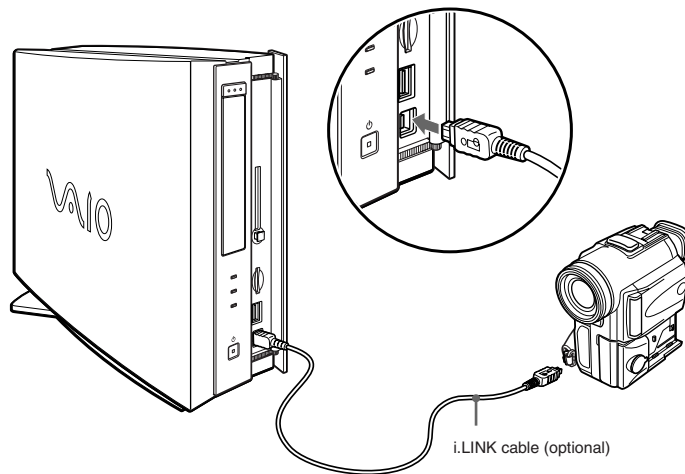

 The i.LINK communication standard that is available in the Windows Me™ operating system is not compatible with the Sony VX1000 camcorder. See the manual that came with your i.LINK-equipped device for more information on installation and use.

## Enabling Ethernet

---

Your computer comes with a preinstalled Ethernet interface. Your computer may ship with the Ethernet function disabled. You can enable Ethernet connectivity by following the instructions below.

### *To enable the Ethernet connection*

- 1 Right-click My Computer on the desktop and select Properties.
- 2 Click the Device Manager tab.
- 3 Select “SiS 900 PCI Fast Ethernet Adapter” under the Network Adapters category.
- 4 Click Properties.
- 5 Click Enable Device and then click OK.
- 6 Click Close.



**Warning:** Your computer has a protective sticker  next to the Ethernet port located on the rear panel. Connect only 10Base-T and 100Base-TX cables to the Ethernet port. Using other cables or a telephone cable may result in an electric current overload and can cause a malfunction, excessive heat or fire in the port. For help on connecting to a network, see your network administrator.

## VAIO® AV Applications

Your VAIO computer comes with a collection of audio and video (AV) applications that make it easy to use advanced multimedia formats. This section describes these VAIO AV applications.

### DVgate™

*Sony Electronics, Inc.*

DVgate software makes it easy to edit digital videos. You can grab and edit digital video clips, and then assemble them into a polished home video everyone will enjoy. You can also use DVgate software to capture individual frames from digital video clips, and then save them as graphic files. Enhance your Web page, send family and friends your favorite stills, create your own wallpaper—the possibilities are endless.

### Media Bar™

*Sony Electronics, Inc.*

Media Bar software is your all-in-one solution for audio/video playback. Media Bar software handles all common computer multimedia formats, and controls certain Sony devices. Media Bar software encompasses audio/video library cataloging and playlist management, in addition to digital video quality control and effects features. Media Bar seamlessly integrates a variety of new media formats with an easy-to-use software interface.

### MovieShaker™

*Sony Electronics, Inc.*

Sony's original MovieShaker software creates personal movies that have transitions, background music, and text. Just import your video clips and "shake" with a click of the mouse. Your personal movies are easy to create and fun to share with family and friends.

### OpenMG™ Jukebox

*Sony Electronics, Inc.*

OpenMG Jukebox software enables you to import digital audio files by downloading from Electronic Music Distribution (EMD) services over digital networks, such as the Internet. You can record audio CDs onto your hard drive in a variety of formats.

### **PictureGear™**

*Sony Electronics, Inc.*

PictureGear is a digital image management application that allows you to see all the images stored in any directory on your computer. Thumbnail views provide quick reminders of your pictures. Brighten, contrast, enhance, resize, crop, and color-correct your pictures. Create panoramic views, animations, screen savers, wallpaper, and even HTML photo albums.

### **Smart Capture™**

*Sony Electronics, Inc.*

Smart Capture is a fun new way to send multimedia messages via e-mail. Smart Capture manages the i.LINK® connection between your computer and a Sony Digital Handycam Camcorder, or other cameras that support the i.LINK interface. Smart Capture allows you to capture and compress video or still images that you can save or share via e-mail. Captures are low resolution, making it ideal for e-mail. For high-quality captures, use DVgate.

 i.LINK is a trademark of Sony used only to designate that a product contains an IEEE1394 connection. The i.LINK connection may vary, depending on the software applications, operating system, and i.LINK-compatible devices. All products with an i.LINK connection may not communicate with each other.

Please refer to the documentation that came with your i.LINK-compatible device for information on operating conditions and proper connection. Before connecting i.LINK-compatible PC peripherals to your system, such as a CD-RW or Hard Disk Drive, confirm their operating system compatibility and required operating conditions.

### **VisualFlow™**

*Sony Electronics, Inc.*

VisualFlow is a state-of-the-art Sony multimedia browser designed specifically for Memory Stick® media. It displays any still picture, movie or sound files stored in a Memory Stick media in a visually pleasing, artistic manner. VisualFlow not only plays a selected movie or sound file, but also enables playback of files by other applications like PictureGear, Memory Stick Slideshow and Windows Explorer.





## MovieShaker™

This application can be used to create fun and innovative movies without any knowledge of film editing. In a few simple steps, motion pictures can be combined with special effects, still images, and music files, and then saved in a format compatible with most computers.

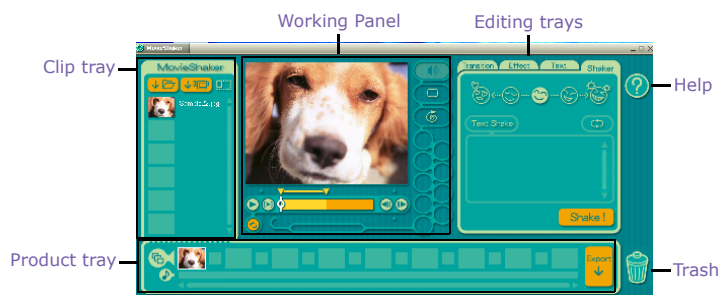
### Main Window



### Importing Images and Sound Clips

- 1 Click  (File Import) or  (DV Import).
- 2 Find the file you want to add.
- 3 Select the file.
- 4 Click Open. The file is added to the Clip tray.

 Importing lengthy image or sound files may cause the MovieShaker software to stop responding.

### Create a Movie using Shaker

After adding clip(s) to the Clip tray, you can create a short movie using the Shaker feature. Shaker randomly selects clips from the Clip tray to create a 30-second scene.

- 1 Click the Shaker tab.
- 2 Select a mood by clicking a face in the Shaker tray.

#### Shaker tray



- 3 Click **Shake !**. A thirty second scene is automatically generated and saved to the Product tray.
- 4 To preview, switch the Work Panel to Product tray mode and press play.

 Scenes created with Shaker begin with a black frame and after processing are placed in the first available slot on the Product tray. Limit the number of scenes placed on the Product tray to 5 or less. MovieShaker software may stop responding if too many scenes are placed on the Product tray.

## Editing Clips and Scenes

You can edit your movie by adding effects and text, adjusting the color and contrast, and modifying the length of clips.

### Working Panel

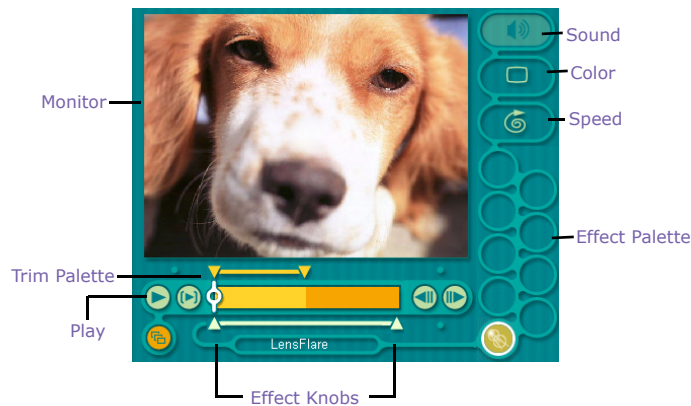

### Adding effects to a scene or a clip

- 1 Double-click the clip or scene to move it to the Working Panel.
- 2 Select the Effects tab from the Editing tray.
- 3 Drag the Effect you want to add from the Effects tray to the Effects palette on the Working Panel.

 To preview an Effect, click the Play button on the Working panel window. Your clip plays the new effect on the Effect tray monitor.

- 4 See Help for instructions on adjusting effect duration and replaying clips and scenes.

### ***Saving a Movie***

- 1** Verify that the clip(s) you want to save is on the Product tray. See Help for more details on saving movies.
- 2** Click Export.
- 3** Select the format in which you want the document to be saved.
- 4** Click Next.
- 5** Locate the folder to which you want the file saved.
- 6** Name the file.
- 7** Click Save.



**Exporting movies may take a long time to complete—“Save movie as DV” (Digital Video) takes the longest and Quick-Save is the fastest. MovieShaker software can play AVI files up to 65 MB in length.**

## ***PictureGear™***

---

PictureGear is a digital image management application that allows you to see all the images stored in any directory on your computer. Thumbnail views provide quick reminders of your pictures. Brighten, contrast, enhance, resize, crop, and color-correct your pictures. Create panoramic views, animations, screen savers, wallpaper, still pictures from MPEG, and even HTML photo albums.

### ***Managing Your Pictures***

Use the collection feature to manage your pictures.

- 1** Click the Folder tab and browse to locate your pictures.
- 2** Select the pictures you want to have in a collection.
- 3** From Collection menu, select Create New Collection.
- 4** Enter a name for the collection and then click OK.

### ***Creating a Photo Album***

- 1** Select the pictures you want to use to make an album.
- 2** From the Utilities menu, select Album Maker.
- 3** Choose the type of Album you want and click OK.
- 4** Now add more pictures, frames, text, and effects.
- 5** When you are finished, select Create Album in File menu or click the Create Album icon on the toolbar.
- 6** Designate the folder where you want to save the Album.
- 7** Enter the Target Album name, select Thumbnails and click OK.
- 8** The new album can be viewed using most internet browsers.

### **Using Panorama Maker**

Panorama Maker stitches a group of still images into a 360 degree panoramic picture. The source images should be the same size and overlap 20%.

How to stitch a panoramic picture:

- 1 Gather the source images into the same folder or collection.
- 2 Select the images you want to use.

 Sony recommends creating your panoramic picture with 12 landscaped or 16 portrait pictures.

- 3 From the Utilities menu select Panorama Maker.
- 4 Select the correct lens and click Okay. (If 35mm lens is selected, the prompt does not appear. To select a different lens, click on the lens icon.)
- 5 Click the panoramic icon, near the bottom of the window.
- 6 Click Full Stitch.

### **Making Still Images and Panoramic from MPEG**

- 1 Select the MPEG file.
- 2 From the Movie/Sound menu, select Scene Break Down.
- 3 Then select Movie Stitch, to create a panoramic picture.

---

## OpenMG™ Jukebox 2.0

---

OpenMG Jukebox is a software application that utilizes Sony Corporation's copyright protection technology. OpenMG Jukebox maintains the holder's copyrights by preventing unauthorized distribution of digital audio files.

OpenMG Jukebox software lets you play and record audio CDs and import digital audio files while maintaining the copyright information of the contents. When you record an audio CD with OpenMG Jukebox, it is encoded in ATRAC3 format onto your computer's hard drive. You can download digital audio files from Electronic Music Distribution (EMD) services. The imported data can be played on your computer or transferred to external devices or media. OpenMG Jukebox converts your existing MP3 and WAV format audio files into OpenMG format (WAV format audio files are converted into ATRAC3 format or changed into OpenMG MP3 format).



**Your VAIO computer ships with OpenMG Jukebox 2.0 installed. Other external devices that are compatible with OpenMG Jukebox may contain an earlier version of the software (Version 1.0, 1.1, or 1.2). Do not install an earlier version of OpenMG Jukebox on your computer, as this may cause the software to work improperly or damage your audio files.**

### *Electronic Music Distribution (EMD) Services*

EMD allows you to download music files via the Internet. To use Internet services that are compatible with OpenMG Jukebox, you need:

- ❑ Access to the Internet from your computer. Sign up with an Internet Service Provider (ISP) and configure your computer for Internet access before using EMD services.
- ❑ An EMD service provider. Consult the provider for information about service.



To protect your personal data, Sony uses Secure Sockets Layer (SSL), an encryption protocol for communication between your browser and Sony's World Wide Web (WWW) server. If you are accessing the Internet from an enterprise Local Area Network (LAN), you may not be able to use SSL due to the proxy server of the LAN. Contact your network administrator for more information.

### **Starting OpenMG Jukebox 2.0**

- 1** From the Start button on the Windows taskbar, point to Programs, point to OpenMG Jukebox, and then click on OpenMG Jukebox.

The CDDB® Music Recognition Service Registration wizard appears. Follow the onscreen instructions to complete registration.

 To register with CDDB, you need Internet access from your computer. For more information regarding CDDB registration, click on the Help button.

- 2** When you have registered with CDDB, the “Set OpenMG Jukebox as the Application for playing Audio CD” dialog box appears. You can set OpenMG Jukebox as the default application for playing audio CDs by selecting the appropriate checkbox.
- 3** Click OK. The OpenMG Jukebox window appears.



**OpenMG Jukebox main window**

- |  |   |
|--|---|
| <p><b>1 Feature tabs</b><br/>Changes the screen view according to the selected feature.</p>                                  | <p><b>5 Internet address drop-down list</b><br/>Displays Internet addresses, if available. You can click on the “Go to URL link” button to immediately connect to Web site.</p> |
| <p><b>2 Player control buttons</b><br/>Controls playback functions, such as play, pause, stop, fast forward and reverse.</p> | <p><b>6 File list view</b><br/>Displays the contents of the folder selected in the file tree view.</p>  |
| <p><b>3 Playlist drop-down list</b><br/>Displays available playlists and audio files of the current feature tab.</p>         | <p><b>7 Tutorial tab</b><br/>Opens and closes the Tutorial feature.</p>   |
| <p><b>4 File tree view</b><br/>Displays the folders available on your computer.</p>  |   |

## Recording a CD

You can record songs from audio CDs and import them to playlists in OpenMG Jukebox.

 When you record from an audio CD on your CD-RW/DVD-ROM drive for the first time, the “CD Drive Optimization” dialog box appears. Click Start to verify your CD-RW/DVD-ROM drive. After the verification is performed, recording begins.

- 1 Insert an audio CD into your system’s CD-RW/DVD-ROM drive.
- 2 Click the CD tab.
- 3 Use the drop-down lists to select the Bit Rate, CD drive, and Record To destination.

### CD tab window

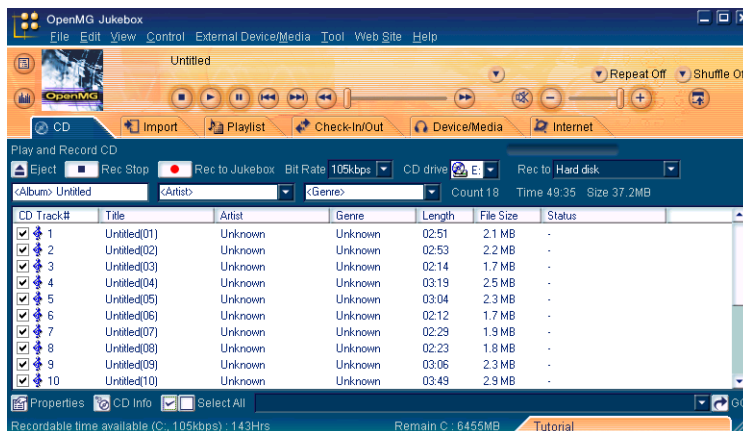

- 4 You can select specific tracks on your CD by removing the checkmark from the tracks you don’t want to record. You can clear all selected tracks by clicking in the empty checkbox next to Select All, and then select the tracks you want to record.
- 5 Click  Rec to Jukebox to begin recording. When the recording is finished, the new playlist appears in the File tree view of the Playlist window. You can change to this feature view by clicking on the Playlist tab.

 You can display the name of the CD and its songs by clicking on the CD Info button.

### Transferring Songs (Check-in/Check-out)

You can transfer songs between the playlists of your OpenMG Jukebox and external devices or media. For more information on using your external devices or media, see the documentation that came with the product.

These instructions are for using the Check-in/Check-out 1 step mode. For information on using 2 step mode, see “Changing the check-in/check-out settings” in the OpenMG Jukebox Help menu.



#### Check-out

- 1 Connect the external device or insert the media into your computer.
- 2 Click on the Check-in/Out tab to display the Check-in/Out tab window. Your computer automatically recognizes the connected external device or media and lists the content information in a new panel on the right side of the Check-in/Out tab window.

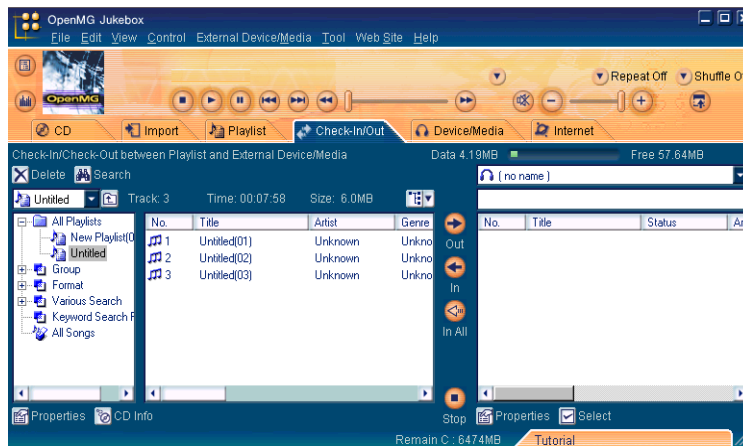
#### Check-In/Out tab window







- 3 Select the playlist that has the song that you want to check out. The songs in the playlist are shown in the Playlist view panel located in the center of the Check-In/Out tab window.
- 4 From the Playlist view panel, select the song to be checked out. To check out more than one song at a time, hold down the Ctrl key and click on the additional songs.
- 5 Click  (Out), or drag the song to the desired position in the song list of the external device or media. Check-out begins.

 To cancel Check-out, click  (Stop), or click Cancel in the Processing dialog box that is displayed during the Check-out process.

### Check-in

 The songs that you transfer to external devices or media can only be checked in to the hard drive of the same computer from which the songs were checked out.

- 1 Connect the external device or insert the media into your computer
- 2 Click on the Check-in/Out tab to display the Check-in/Out tab window. Your computer automatically recognizes the connected external device or media and lists the content information in a new panel on the right side of the Check-in/Out tab window.
- 3 Select the song to be checked in from the song list of the external device or media. To check in more than one song at a time, hold down the Ctrl key and click on the additional songs.
- 4 Click  (In), or drag the song(s) to the Playlist view panel. If you want to check in all of the songs in the external device or media, click  (In All). Check-in begins.

 To cancel check-in, click  (Stop), or click Cancel in the Processing dialog box that is displayed during the Check-out process.

For more information about using OpenMG Jukebox 2.0 software, go to the online OpenMG Jukebox Help. You can access the online help file using either of the following instructions:

- ❑ Click the Start button on the Windows taskbar, point to Programs, point to OpenMG Jukebox, and then click on OpenMG Jukebox Help.
- ❑ From the OpenMG Jukebox Help menu, select OpenMG Jukebox Help.

### ***Additional Features***

- ❑ **OpenMG Jukebox Tutorial** — The features of OpenMG Jukebox 2.0 are described in the Tutorial. The user friendly interface guides you directly to the OpenMG Jukebox 2.0 features.
- ❑ **OpenMG Jukebox Backup Tool** — You can back up and restore all of the music, graphics and information data managed by OpenMG Jukebox. You must be connected to the Internet to use the OpenMG Jukebox Backup Tool.
- ❑ **Import audio files in various formats** — You can import audio files with various formats, such as MP3 or WAV standards. You can also import audio files that comply with the Microsoft® Windows Media™ Technologies (WMT) standard, identified by .asf or .wma extensions. Manage your audio files through the Playlist feature of OpenMG Jukebox 2.0.
- ❑ **Manage imported songs on the Playlist** — Additional features are available when you register your imported songs through the Playlist feature of OpenMG Jukebox. You can manage your music by creating your own list of songs categorized by genre or artist, displaying your song list in the Playlist feature, and arranging your songs in a customized order using the Playlist folders. Edit your music by combining multiple songs into a single song, or divide one song into two, by using the Combine and Divide features.
- ❑ **Simple mode** — The main OpenMG Jukebox window in simple mode is a smaller, compact version of the full mode view. This can be useful when you want to listen to songs with OpenMG Jukebox while using other software, or whenever you feel that full mode view is intrusive. The design of the main OpenMG Jukebox window in simple mode can be changed by adding a new “skin” which enhances the window’s appearance. The Simple mode feature allows you to perform playback operations only.



|   |  |
|---|--|
| <b>1 Mode indicator</b><br>Displays the current mode (Still or Net Movie).  | <b>5 Help button</b><br>Connects you directly to the online Smart Capture help.  |
| <b>2 Mode dial</b><br>Switches Smart Capture from Still mode to Net Movie mode with a single click of your mouse. | <b>6 Capture button</b><br>Captures your individual still images in the same manner as a camera. You can select different characteristics for the Capture button when capturing a Net Movie. |
| <b>3 Options button</b><br>Displays the configuration options available for either Still or Net Movie mode.       | <b>7 Application Switch drop-down list</b><br>Switches between the Still image and Net movie modes, using a drop-down list.  |
| <b>4 Effects button</b><br>Displays the special effects that you can apply to your pictures or video clips.       | <b>8 Image window</b><br>Displays the still or video image from your digital camera or camcorder   |

### Using Still mode

- 1 From the Start button, point to Programs, point to Smart Capture, and then click on Smart Capture. The Smart Capture main window appears.
- 2 Connect your i.LINK-compatible digital camera or camcorder to your computer with an i.LINK cable. An image appears in the Smart Capture main window.

 The Smart Capture main window opens with a blue screen image, indicating that there is no data input from a digital camera or camcorder. When you connect your digital camera or camcorder to your system with an i.LINK cable and turn it on, an image appears in the main window. Some cameras and camcorders need to have a recording media inserted before an image can be displayed in the Smart Capture window. Consult the manual that came with your digital camera or camcorder for more information.

- 3 Check that the Mode dial is set to Still. Click on the Mode dial to switch between Still mode and Net Movie mode.

- 4 Click on the Options button to view the available options for your still image capture. The Still Image Options window appears.

*Still Image Options window*

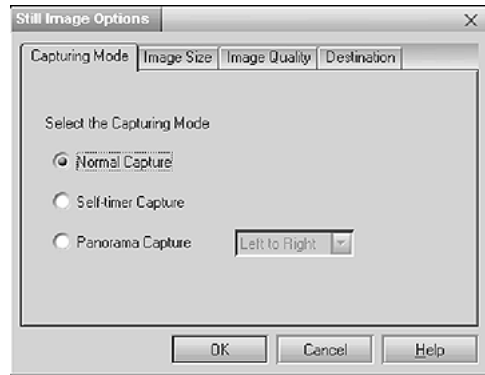



The Still Image Options window has four tabs:

- ❑ **Capturing Mode:** — You can choose between Normal, Self-timer or Panorama Capture modes.
  - ❑ **Image Size:** — Select the image size, horizontal by vertical in pixels.
  - ❑ **Image Quality:** — Set the quality of your pictures as they are being saved by selecting Fine, Standard or Economy image quality.
  - ❑ **Destination:** — Select a file destination for your pictures.
- 5 Click on the Effects button to select a special image effect. The Effect Setting window appears. Use the drop-down list to view and customize the available effects.

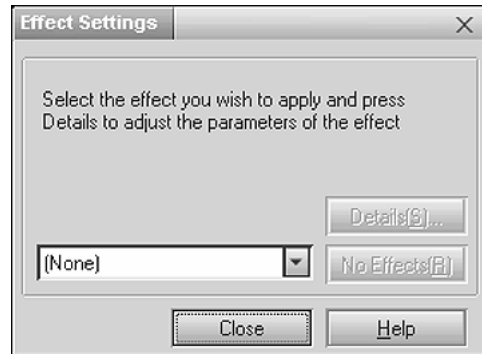

**Effect Setting window**



 You can use a different special effect for each picture, or you can remove all special effects by clicking on the No Effects button.

### *Capturing a picture in Still mode*

- 1 Use your digital camera or camcorder to locate the image you want to capture. When you see the desired image in the Smart Capture window, click on the Capture button. The Still Viewer window appears. You can capture one picture or several pictures at a time.

### *Still Viewer window*

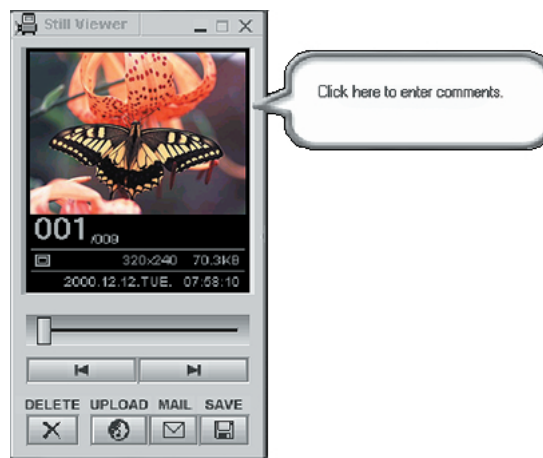

- 2 Click on the arrows or drag the scroll bar to view the pictures. As each image is captured, it displays in the Still Viewer window with a balloon for your comments and an identifying number in the viewer's queue.

### *Managing pictures in Still mode*

From the Still Viewer window, you can perform various functions using the task buttons:

- **Delete** — Discard any or all of your still images by clicking on the Delete button. Select a single image or all and the image(s) is “torn” and removed from the Still Viewer window.

- ❑ **Upload** — Send your still images online to the ImageStation Web site to share with your family and friends. ImageStation stores your still images online when you register for this free service. See “Using ImageStation™.”
- ❑ **Mail** — E-mail your still images to your family and friends. Click on the Mail button and your e-mail application launches with a new message window containing the still image.
- ❑ **Save** — Click on the Save button to save your still image in a variety of formats, to a location of your choice.

 You must be connected to the Internet before attempting to upload or e-mail your still images or videos.

### *Using Net Movie mode*

- 1 From the Start button on the Windows taskbar, point to Programs, point to Smart Capture, and then click on Smart Capture. The Smart Capture main window appears.
- 2 Connect your i.LINK-compatible digital camcorder to your computer with an i.LINK cable. An image appears in the Smart Capture main window.
- 3 Check that the Mode dial is set to Net Movie. Click on the Mode dial to switch between Still mode and Net Movie mode.

- 4 Click on the Options button to view the available options for your movie capture. The Recording Options window appears.

#### Recording Options window

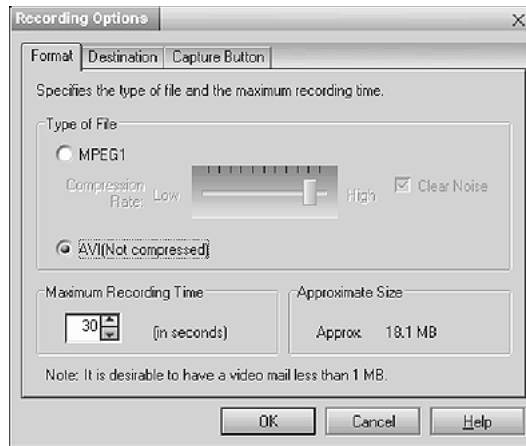

The Recording Options window has three tabs:

- ❑ **Format:** — You can adjust the compression rate for your movies in MPEG1 format or choose the AVI option for no compression. You can also set the maximum recording time for your movie capture.
  - ❑ **Destination:** — Select a file destination for your movies when recording video clips.
  - ❑ **Capture Button:** — Set the characteristics of the Capture button. You can start and stop recording by pressing the Capture button (this is the default characteristic). You can select Anti-Ground Shooting, which allows recording to occur only while the Capture button is pressed. Recording will stop when you release the button.
- 5 Click on the Effects button to select a special image effect. The Effect Setting window appears. Use the drop-down list to view and customize the available effects.

 You can remove all special effects by clicking on the No Effects button.

### *Capturing a movie in Net Movie mode*

- 1 Use your digital camcorder to locate the view(s) you want to capture. When you see the desired view in either the Smart Capture window or your camcorder's viewfinder, press the Capture button to begin recording your movie. The Movie Player window appears.
- 2 Click on the Capture button when you have finished recording your movie and the first frame of your movie appears in the Movie Player window. You can record a movie for approximately thirty seconds. The Movie Player feature will automatically stop recording when this time limit is reached.

 If you have set the Capture button to use the Anti-Ground setting, you must press and hold the Capture button to continue recording.

### *Movie Player window*



- 3 You can review your movie from the Movie Player window by using the play, pause and stop buttons. Click on the arrows or drag the scroll bar to view your movie. Each frame is displayed with an identifying number in the queue.

### *Managing your movie in Net Movie mode*

From the Movie Player window, you can perform various functions using the task buttons:

- ❑ **Delete** — Discard any frame or the entire movie by clicking on the Delete button. The frame or movie is removed from the Movie Player window.
- ❑ **Upload** — Compress and send your movies online to the ImageStation Web site to share with your family and friends. ImageStation stores your movies online when you register for this free service. See “Using ImageStation™.”
- ❑ **Mail** — E-mail your movies to family and friends. Click on the Mail button and your e-mail application launches with a new message window containing the movie.
- ❑ **Save** — Click on the Save button to compress and save your movie in a variety of formats, to a location of your choice.

### *Using ImageStation™*

ImageStation is a free online service that allows you to store your pictures and movies on the Internet to share with family and friends. ImageStation requires an Internet connection and registration for the Web-based service. You must be connected to the Internet before uploading your pictures or movies with Smart Capture and ImageStation.

### *Uploading with Movie Player*

 Sony recommends that your movie file size not exceed 254 MB if compressed, or 2 GB if not compressed. Large movie files take longer to upload to the ImageStation Web site.

- 1 Click on the Upload Button in Movie Player. The Compression Settings when Uploading window appears.

- 2 Select the compression rate and press the Start Compression button. The ImageStation Login window appears. See steps 2 - 4 in the next section, “Uploading with Still Viewer” for further uploading information.

**Compression Settings when Uploading window**

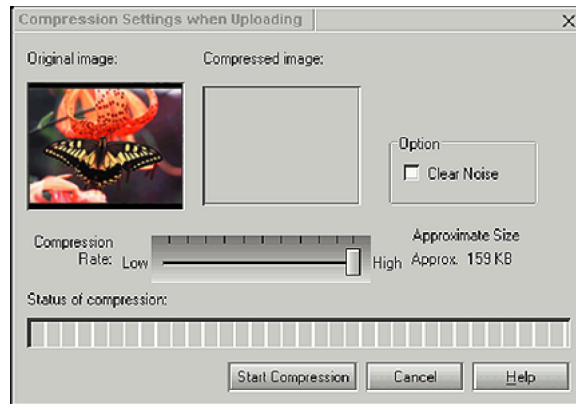

**Uploading with Still Viewer**

- 1 Click on the Upload button in Still Viewer. The ImageStation Login window appears.

**ImageStation Login window**



- For first time users, the ImageStation registration wizard guides you through the initial registration process. Follow the onscreen instructions. If you are already a registered member, provide your login name and password. The Image Uploader window appears.

**Image Uploader window**

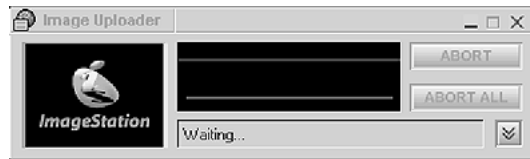

- From the Still Viewer or Movie Player window, click on the Upload button to transfer your pictures or movies to the ImageStation Web site. The Image Uploader window displays your Internet connection and upload status. Click on  to see thumbnail previews of your pictures or movies.

 The ImageStation preview feature is available when you upload two or more pictures or a movie. No preview is shown if a single picture is being uploaded.

- Go to <http://www.imagestation.com> to view your uploaded pictures or movies. Follow the onscreen instructions to access your ImageStation account. The ImageStation Web site may ask you to complete a full login again, if your current session is not active.



## VisualFlow™

VisualFlow is a Sony state-of-the-art multimedia browser designed specifically for Memory Stick media. It displays any still picture, movie or sound files stored in a Memory Stick media in a visually pleasing, artistic manner. VisualFlow plays a selected movie or sound file, and enables playback of files by other applications like PictureGear™, PictureToy™, Memory Stick Slideshow and Windows® Explorer.

### To use VisualFlow

- 1 From the Start menu, point to Programs, point to VisualFlow, and then click on VisualFlow.

 If your system is Memory Stick-compatible, the VAIO Action Setup may be configured to launch the VisualFlow browser upon insertion of a Memory Stick media. In this case, VisualFlow starts automatically when a Memory Stick media is inserted.

- 2 Click on an icon in the View section on the main toolbar to select a display layout.
- 3 Click on an icon in the Sort section on the main toolbar to select a sorting method.
- 4 Placing your cursor on the left end of the main toolbar activates the current Memory Stick properties.
- 5 Placing your cursor on the right end of the main toolbar activates a secondary toolbar with more functions.
- 6 Click on an image to show a normal view centered on the screen.  
Double-clicking an image shows an enlarged view.
- 7 The movie file starts playback when the view is enlarged. Click again on the movie files to restore the view to normal.

 While an image is enlarged, the Launch toolbar appears at the bottom of the window. Any associated application can be activated from this point.

## DVGate™

---

### *Connecting a digital video camera recorder*

Before connecting a digital video camera recorder to your computer, turn off the power on the camera. After connecting the camera, turn the power back on. You do not need to turn off the computer when connecting a camera.

### *Using DVgate™ software with a digital video camera recorder*

#### *When capturing clips*

- ❑ Do not use DVgate software when the connected digital video device is in Timer Recording mode, as this could produce a malfunction in the device.
- ❑ Captures larger than 2 GB (9 minutes and 30 seconds) are automatically continued in a second file.
- ❑ You can record stereo audio (stereo 1) while capturing video or you can add audio on the stereo 2 track after capturing the video data.
- ❑ You cannot use different audio modes on the same tape. You should perform a separate capture for each audio mode you wish to use.
- ❑ DVgate software does not support hard disk compression. You should not use disk compression if you are planning to work with DVgate.
- ❑ Title data is saved in the flash memory of a digital video camera and is not transferred to tape by DVgate software.
- ❑ To avoid interruption of capture sessions, you should disable the screen saver.
- ❑ The drop frame compensation feature does not provide accurate compensation adjustments for tapes recorded in LP mode.
- ❑ For tapes that include a mixture of both SP and LP mode, the information displayed by the capture progress indicator may not be accurate.
- ❑ Make sure the video head of your digital video device is properly cleaned. Anomalies that you see in captured data could be due to dust or other particles on the video head.
- ❑ The last frame captured is one frame before your selected [OUT] point. The frame you see immediately after clicking the [OUT] button is not captured.

***When recording AVI files to tape***

- ❑ Do not use DVgate software when the connected digital video device is in Timer Recording mode, as this could produce a malfunction in the device.

 You can record only AVI files. MPEG files cannot be recorded.

- ❑ To avoid recording problems, such as a single frame appearing in multiple frames, close other applications on your system while recording.
- ❑ You cannot use different audio modes on the same tape. If you have AVI files that use different audio modes, they cannot be recorded at the same time, but must be recorded separately.
- ❑ Do not attempt to work with AVI files that are smaller than 4 MB.
- ❑ DVgate software does not support hard disk compression. Do not use disk compression if you are planning to work with DVgate.
- ❑ In order to maximize recording capabilities, video and audio data are not available while you are recording.
- ❑ If DVgate software indicates that frames have been dropped, close all open applications, or defragment your hard drive.



# System, Application and Driver Recovery CD(s)

## System Recovery CD(s)

*Sony Electronics*

The System Recovery CD program allows you to restore the software titles that shipped with your computer if they become corrupted or are erased. It can be used only to restore the hard disk of the Sony computer you purchased. VAIO Slimtop™ LCD Computer User Guide

## Application Recovery CD(s)

*Sony Electronics*

The Application Recovery CD program allows you to reinstall individual applications. Use it to restore corrupted or erased files.

## Driver Recovery CD

*Sony Electronics*

The Driver Recovery CD program allows you to reinstall individual device drivers. Use it to restore corrupted or erased files.

## Using the System Recovery CD(s)

You can reinstall software titles that shipped with your computer if they become corrupted or are erased. You may not need to recover the entire contents of your hard drive. If you experience a problem with your computer, reinstalling a software title may correct the problem.

 Use the Application Recovery CD program to reinstall individual applications.

### **Full Restore with Format**

The System Recovery utility formats your hard disk drive, and then restores all the original software.



**You will lose any software you have installed and any other files you have created since you started to use your computer. You must reinstall any applications that were not included with the computer when you purchased it.**

### ***To use the System Recovery CD(s)***

 You need to complete the Windows registration process when you use the System Recovery CD(s).

- 1 Insert the Sony System Recovery CD in the CD-RW drive.

 The System Recovery utility boots from the CD-RW drive. It must be in the drive when you turn on the computer.

- 2 Shut down your computer.
- 3 Wait 30 seconds and turn on your computer.
- 4 Click OK to signify you have read and accepted the Microsoft End-User License Agreement.
- 5 When the System Recovery menu appears, follow the on-screen instructions to complete the recovery process.

 Your system may include one or more System Recovery CDs. If you have more than one System Recovery CD, insert the first CD to run the System Recovery program. You are prompted to insert the next CD(s) once the information from the first CD has been installed.

The recovery process takes 30 to 60 minutes to complete.

After recovering your system using the System Recovery CD(s), you may be prompted to insert your Application Recovery CD(s) after restarting Windows. Use the Application Recovery CD(s) to complete the full recovery of your system.

### ***Using the Application Recovery CD(s)***

---

The Application Recovery CD utility allows you to reinstall individual applications if they become corrupted or are erased. Reinstalling an individual software title may correct a problem that you are experiencing with your computer or software application. You may not need to reinstall the entire contents of your hard drive.

 If you need to reinstall all the software titles that shipped with your computer, use the System Recovery CD(s).

You must be in Windows to run the Application Recovery CD utility. If you have any questions on using the Application Recovery CD(s), contact Sony Customer Support.

### ***To use the Application Recovery CD(s)***

- 1** Turn on your computer. If your computer is already on, close all applications.
- 2** When the Windows desktop appears, insert the Application Recovery CD in the CD-RW drive. The Application Recovery utility loads automatically.
- 3** When the Application Recovery menu appears, follow the on-screen instructions to complete the recovery process.

 Your system may include one or more Application Recovery CDs. If you have more than one Application Recovery CD, insert the first CD to run the Application Recovery utility. You may be prompted to insert the next CD(s), depending on the application you wish to restore.

## ***Using the Driver Recovery CD***

---

The Driver Recovery CD utility allows you to reinstall individual drivers and repair software applications if they become corrupted or are erased. You can reinstall an individual driver to correct a problem that you are experiencing with your computer, hardware, or software application. VAIO Support Agent, an application repair utility, uses a vault feature on the Driver Recovery CD during its software healing process.

 A list of software titles that are protected by VAIO Support Agent can be located in the section, "Using the VAIO Support Agent." If you need to reinstall all of the software titles that shipped with your computer, use the System Recovery CD(s)

You must be in Windows to run the Driver Recovery CD utility.

***To reinstall drivers with the Driver Recovery CD***

- 1 Turn on your computer. If your computer is already on, close all applications.
- 2 When the Windows desktop appears, insert the Driver Recovery CD in the CD-RW drive. Use My Computer or Windows Explorer to view the contents of the Driver Recovery CD. Select the appropriate driver.

***To repair software applications using VAIO Support Agent***

The Driver Recovery CD utility has an information vault that contains the original characteristics for the preinstalled software applications that are protected by VAIO Support Agent. See “Using the VAIO Support Agent” for instructions on how to fix your software problems.



## Using the VAIO Support Agent

VAIO Support Agent helps you repair your own software problems without the assistance of a support analyst. VAIO Support Agent's advanced diagnostic technology identifies and tracks characteristics of your software applications, Internet configuration, and operating system components. These diagnostics protect and store information in a retrievable format that allows you to restore your software to a previous working state. The software and operating system items you can fix are those identified by Sony as protected by VAIO Support Agent.

VAIO Support Agent has three features to help you fix your software problems: Quick Fix Wizard, Common Solutions, and Support Central. This section briefly describes these three features.

### VAIO Support Agent main screen



## Using the Quick Fix Wizard

The Quick Fix Wizard automatically checks your system when a problem occurs and brings your software back to a previous working state.

- 1 Click the Quick Fix Wizard button.

### Quick Fix Wizard: Begin Support.com Diagnostics screen

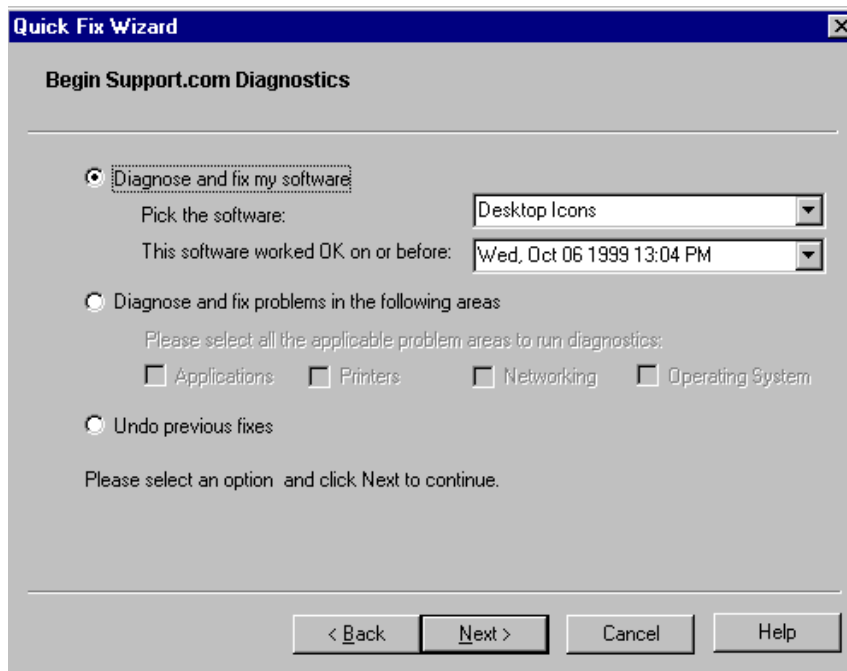

- 2 When the Welcome screen appears, click Next.
- 3 If you know which software is causing the problem, click Diagnose and fix my software. If you are unsure of what is causing the problem, click Diagnose and fix problems in the following area and select the items you want VAIO Support Agent to examine.
- 4 Click Next to continue.
- 5 Follow the instructions on the screen.

## Using Common Solutions

Common Solutions offers automated, One-Click Fixes to repair common software problems. These solutions can integrate information such as knowledge base articles and Frequently Asked Questions (FAQs). You can run One-Click Fixes directly from VAIO Support Agent or from a web browser.

- 1 Click the Common Solutions button.

### Common Solutions: Browse for SupportActions screen

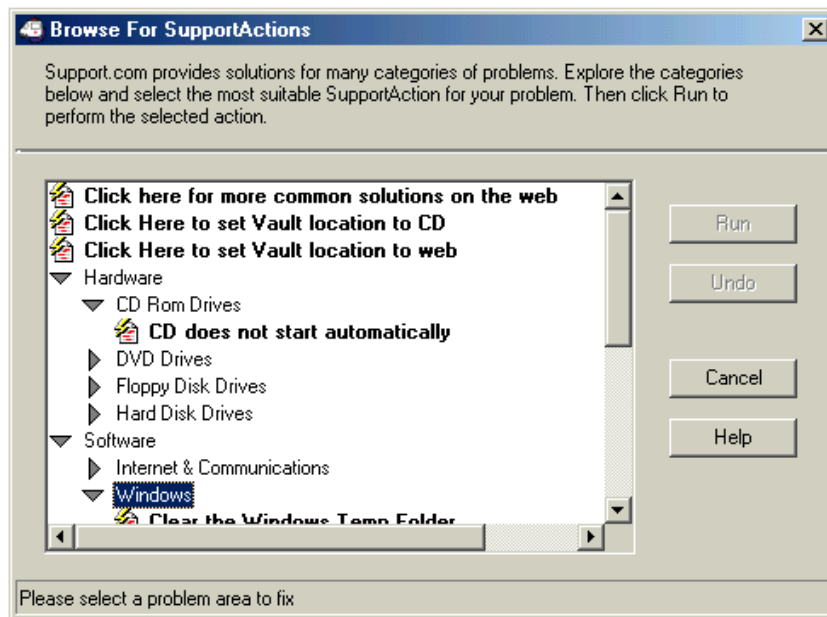

- 2 Click the arrows next to the SupportAction categories to expand and collapse the list.
- 3 Select a SupportAction from the list.
- 4 Click Run, or double-click the selected SupportAction.

 You cannot undo One-Click Fixes.

## Using Support Central

Support Central uses Internet resources to help you self-service your software. Support Central searches the Internet for answers to your questions, additional information from knowledge-based systems, and the latest software updates for your protected software. Support Central also lets you contact live support agents for additional information and interaction.

- 1 Connect to the Internet.
- 2 Click Support Central. The Support Central Welcome page appears.
- 3 The Welcome page displays the available security levels for your current Support Central session. Select the desired security option, and then click Enter Portal.

 You must have Internet access to use Support Central.

### Support Central: Welcome

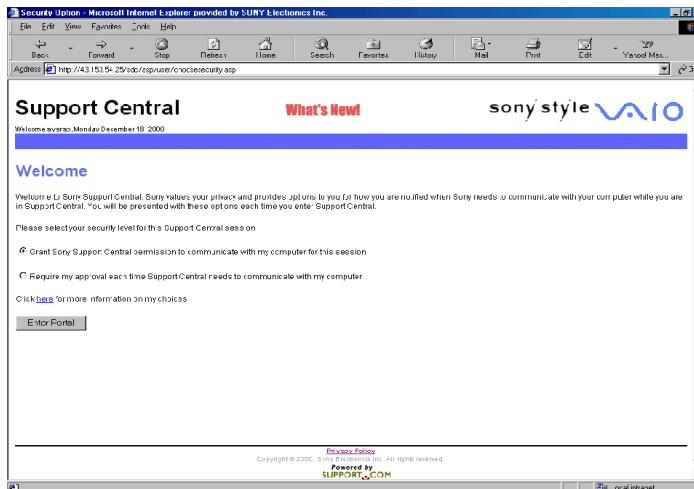

- 4 First-time users will be asked to register with Support Central. Follow the onscreen registration instructions.

 Support Central retains your registration information, so you are only required to register once. If you log on to your computer with a different user name or have recovered your system using the System Recovery CDs, Support Central may require another registration.

### Support Central: Registration

- 5 Support Central has a tracking feature that stores the issues you are currently working on. When you log on to Support Central, a Current Issues page displays, allowing you to continue working on your open issues or to close them if you are finished.

Support Central: Current Issues

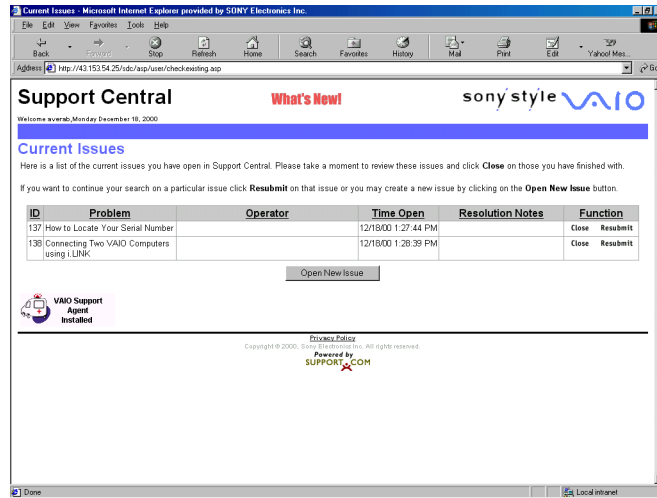

- When you log on to Support Central with a new issue, or if you do not have any open issues, the Support Wizard appears. You can begin searching on the new issue.

## Support Central: Support Wizard

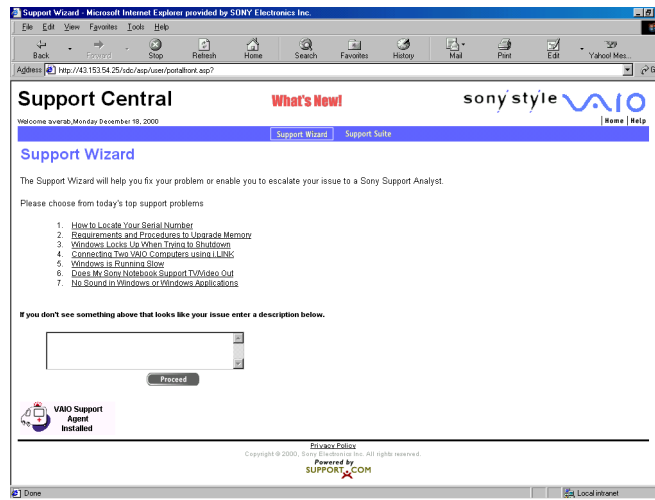

 For more information on using VAIO Support Agent, see the online help.

## **Software Applications protected by VAIO Support Agent**

---

In addition to the software listed below, your system's drivers, basic network settings and modem settings are protected by the VAIO Support Agent utility.

### **Utilities**

- VAIO Action Setup

### **Applications**

- Adobe® PhotoDeluxe® Home Edition
- Adobe® Premiere® LE
- DVgate™
- PictureGear™
- MovieShaker™
- Media Bar™
- OpenMG™ Jukebox
- Sound Forge® XP
- Direct CD™
- Easy CD Creator™

 The VAIO Support Agent utility may ask you to use the Driver Recovery CD during the healing process.



# Troubleshooting

*This section describes how to solve common problems you may encounter when using your computer. Many problems have simple solutions, so try these suggestions before you call Sony Customer Support.*

## Topics

---

### *Topic: My computer does not start*

- ❑ Check that the computer is plugged into a power source and that it is turned on. Check that the power light is lit on the front panel of the computer.
- ❑ Confirm that a diskette is not in the diskette drive (unless you are using a bootable diskette).
- ❑ Confirm that the power cord and all cables are connected firmly.
- ❑ If you plugged the computer into a power strip or Universal Power Supply (UPS), make sure the power strip or UPS is turned on and working.
- ❑ Check that the display is plugged into a power source and turned on. Check that the brightness and contrast controls are adjusted correctly. See the manual that came with your display for details.
- ❑ Check that the computer is not in standby mode.

### *Topic: My computer or software program stops responding*

- 1 Press Ctrl+Alt+Delete to close the application that has stopped responding
  - 2 In the Close Program dialog box, scroll down until you locate the message “Not responding” next to an application.
  - 3 Select this application and click End Task. Windows attempts to close the application. If the attempt is unsuccessful, a second dialog box appears.
  - 4 Select End Task again.
- ❑ If you are unable to “unlock” the application, repeat the above steps but select Shut Down when the Close Program dialog box appears.

- ❑ If the above steps fail to “unlock” your computer, try the following steps:
  - 1 Save any unsaved work, if possible.
  - 2 Press Alt+F4.
  - 3 Select Restart.
  - 4 Click OK.
- ❑ If you cannot restart as described in the preceding steps, you can restart the computer by pressing Ctrl+Alt+Delete or by pressing the power switch for more than six seconds.

 Pressing Ctrl+Alt+Delete twice consecutively may result in the loss of changes made to files that are currently open.

- ❑ Contact the software publisher or designated provider for technical support. See the contact information in this manual.

***Topic: Windows® Millennium Edition operating System locks up during shutdown***

The Windows Me™ operating system may not shut down properly for many reasons, including incompatible or conflicting drivers, damaged files, or non-responsive hardware. For troubleshooting information, you can search Windows Help.

- 1 From the Start menu, select Help. Microsoft Help and Support appears.
- 2 Click on Troubleshooting and continue clicking on the subject(s) for which you want information.
- 3 When you find the appropriate information, close the Help and Support.

***Topic: My CD-RW drive tray does not open***

- ❑ Use the eject button
  - 1 Make sure the computer is turned on.
  - 2 Press the Eject button on the drive.
- ❑ Use the My Computer icon
  - 1 Click the My Computer icon on the Windows® desktop.

- 2 Right-click the CD-RW icon.
- 3 Select the Eject option from the pop-up menu.

*Topic: I cannot play a CD*

- After inserting your CD, wait a few seconds for it to be detected before trying to access it.
- Make sure you place the disc in the tray with the label side facing up.
- Make sure the software is installed according to the program's instructions.
- If your drive reads some CDs, but not others, check the shiny side of the disc for dirt or scratches. You may also need to clean the disc drive lens with an appropriate cleaner.

*Topic: I want to play a CD with my Microsoft CD Player*

When you insert a music CD, the Sony Media Bar™ automatically launches to play your CD. When the Sony Media Bar is running, the Microsoft CD Player does not have access to the CD. Close Media Bar to use the Microsoft CD Player. If you do not hear any music, check all your volume controls.

*Topic: When I click an application icon, a message such as “You must insert the application CD into your drive” appears and the software does not start*

- Some titles require specific files that are located on the application's CD. Insert the disc and try starting the program again.
- Check to make sure you inserted the CD with the label side facing up.

**Topic: Why doesn't my CD-RW drive record at the highest speed?**

You must use 8x CD-R or 4x CD-RW media to achieve optimum performance.

 The VAIO Slimtop™ computer has a maximum record rate of 8x for CD-R and 4x for CD-RW media.

If you must use other media and are having difficulty formatting non-4x CD-RW media, change the write speed from 4x to a lower setting. Follow these steps to switch the write speed to a lower setting.

- 1 From the Start menu, select Programs > Adaptec Easy CD Creator 4> Create CD
- 2 Click Audio, then click Audio CD.
- 3 On the Tools menu, click CD Drive Properties. The CD Drive Properties dialog box appears.
- 4 At the Write Speed drop-down list, select 2x or 4 x.
- 5 Click Close.

 Your CD-RW drive is assigned drive G: as its default.

 1X writing is not supported.

**Topic: How do I change the video resolution of my display?**

- 1 From the Start menu, select Settings > Control Panel.
- 2 Click the Display icon and select the Settings tab.
- 3 Move the Display area slider to change the resolution.
- 4 Click OK.

**Topic: The cursor on my Sony Pen Tablet display does not move or moves in an unpredictable manner when I use the VAIO pen.**

You may need to reconfigure your pen's switch functions.

*Topic: Why doesn't my mouse resume operation as my input device when I stop using the VAIO Pen?*

A conflict occurs between the pen and another input device while the pen is in contact with the Sony Pen Tablet display screen. When you are finished using your VAIO pen, do not leave it on the tablet screen. Place the pen in the supplied pen stand when it is not in use.

*Topic: I cannot draw or erase on the Sony Pen Tablet display with my VAIO Pen.*

This may occur when you move to different applications or windows where the Sony Tablet Set Up program is not loaded. The application or window will return to its normal state when the pen tip is removed from the tablet screen.

*Topic: My VAIO Pen does not respond correctly when my computer returns to Normal mode (from Standby or Suspend modes).*



When the VAIO Pen is left too close to the tablet and your system is returning from Standby or Suspend modes, your VAIO Pen or Sony Pen Tablet settings may change. These symptoms and their solutions are listed as follows:

- ❑ If the VAIO Pen does not move the cursor or the Rocker switch does not work, you must restart your computer. Save all open documents and close all open applications with your mouse, before you restart your computer.
- ❑ If the tablet mouse (UD cursor) appears to be the default setting in the Sony Tablet software, you can go to the Sony Tablet Property window and select Edit-Reset Settings to cancel this registration.

*Topic: Why is there no sound in any application?*

There are independent controls for your system volume.

- ❑ Check that the speakers are plugged correctly into the HEADPHONES jack.
- ❑ If the speakers have a mute button, make sure it is off.
- ❑ If the speakers are powered by batteries, check that the batteries are inserted properly and that they are charged.
- ❑ If the speakers use an external power source, make sure that the power cord is plugged into a grounded wall outlet or power strip.
- ❑ If the speakers have their own volume control, check the volume level.

- ❑ If the program you are using has its own volume control, check that the volume is turned up.
- ❑ Check the volume controls in the application, in the audio mixer, and in Windows. There is a volume control  on the Windows® taskbar. Click the icon and slide the level bar up to increase the volume.
- ❑ Check that the Mute check box is not selected in the Windows volume control .
- ❑ If you connected headphones to the computer, you will not hear sound from the speakers.

*Topic: My modem connection is slow*

The computer's modem uses Lucent technology/V.90. Many factors influence modem connection speed, including telephone line noise or compatibility with telephone equipment (such as fax machines or other modems). If you think your modem is not connecting properly to other PC-based modems, fax machines, or your Internet Service Provider, check the following:

- ❑ Have your phone company check that your phone line is free from any line noise.
- ❑ If your problem is fax-related, check that there are no problems with the fax machine you are calling and that it is compatible with fax modems.
- ❑ For optimum performance, ensure you are calling an Internet Service Provider number that is V.90-compliant.
- ❑ If you are having a problem connecting with your Internet Service Provider, check that the ISP is not experiencing technical problems.
- ❑ If you have a second phone line available, try connecting the modem to this line.

*Topic: My modem does not work*

- ❑ Check that the phone line is plugged into the LINE jack.
- ❑ Check that the phone line is working. You can check the line by plugging in an ordinary phone and listening for a dial tone.
- ❑ Check that the phone number the program is dialing is correct.
- ❑ Verify that the software you are using is appropriately configured to recognize and interact with the Sony computer modem. Call the software publisher if you do not know how to configure the software to recognize the modem. All programs preinstalled by Sony are compatible.

- If you suspect your modem is not functioning, you can perform a simple test to find out.
  - 1 Click the My Computer icon on your desktop.
  - 2 Click Control Panel.
  - 3 Click Modems.
  - 4 Click the Diagnostics tab.
  - 5 Select COM3.
  - 6 Click More Info.

If your modem is functioning, a More Info dialog box will display. If your modem is not functioning, an error message will appear.

*Topic: How do I change my modem to rotary or Touch-Tone dialing?*

- 1 Click the My Computer icon on your desktop.
- 2 Click Control Panel and then click Modems.
- 3 Click Dialing Properties.
- 4 Select the Tone dial or Pulse dial option next to “Dial using.”
- 5 Click OK.

*Topic: My microphone does not work*

Check that the microphone is plugged into the MIC jack.

*Topic: My microphone is too sensitive to background noise*

If you find there is too much background noise when you record sound, you should adjust the microphone gain by following these steps:

- 1 Right-click the speaker icon (Volume) in the lower-right Windows<sup>®</sup> task tray.
- 2 Click Open Volume Controls.  
The Volume Control screen appears.
- 3 In the Options menu, select Properties.  
The Properties screen appears.

- 4 Change the setting for “Adjust volume for” from Playback to Recording, then click OK.
- 5 Decrease the microphone level.
- 6 If available, click the Advanced button under Microphone Balance.  
The Advanced Controls for Microphone screen appears.
- 7 Deselect the check box for 1 Microphone Boost, then click the Close button.
- 8 Close the Recording Control window.

*Topic: My mouse does not work*

- Check that the mouse is plugged into the MOUSE port on the Sony Pen Tablet.
- There may be dust or dirt inside the mouse mechanism. To clean the mouse, follow these steps:
  - 1 Turn off your computer and turn the mouse upside down.
  - 2 Remove the mouse ball cover on the back of the mouse by turning clockwise the ring that covers the mouse ball.
  - 3 Turn the mouse upright, and drop the mouse ball into your hand.
  - 4 Using a piece of tape, remove any dust or dirt on the mouse ball and inside the mouse ball socket.
  - 5 Return the mouse ball to the socket, and replace the mouse ball cover. Secure the cover by turning the ring counter-clockwise.

*Topic: My mouse needs to be set up for left-hand use*

- 1 Click the My Computer icon on your desktop.
- 2 Click Control Panel, and then click Mouse.
- 3 In the Buttons tab, select Left-handed under the Button Configuration options.
- 4 Click Apply, then OK

*Topic: My keyboard does not work*

Check that the keyboard is plugged into the KEYBOARD port.



*Topic: I cannot find the Windows® taskbar*

- ❑ Check that the taskbar is not hidden or shrunken.
- ❑ Use the mouse to point to the left, right, top, and bottom edges of the screen.

*Topic: Why is my system running slowly?*

- ❑ The system responsiveness varies depending on the number of applications that are open and running. Close any applications that you are not currently using.
- ❑ Increasing the system memory may also help. The computer has two memory slots. For memory upgrades, use only 3.3V 64-bit PC-133 SDRAM DIMM modules. For information on installing memory, please see the online manual, “*Upgrading and Maintaining Your Slimtop™ LCD Computer*” .

*Topic: My i.LINK® device does not appear on the desktop*

- 1 Turn off and disconnect your device.
- 2 Reconnect your device.
- 3 Then turn on the power.

*Topic: My connected printer doesn't function after the computer resumes from a power saving mode*

When this occurs, follow the procedures below to reset the printer connection:

- 1 Right-click the My Computer icon on the desktop, and then select Properties.
- 2 Click the Device Manager tab.
- 3 Select Refresh, and then click OK.
- 4 The printer should now function properly.

*Topic: How do I enable my Ethernet interface?*

- 1 Click on My Computer icon on the desktop.
- 2 Click on Control Panel, and then click on System.
- 3 Click the Device Manager tab.

- 4 Click on the Network Adapters category, and then select “SiS 900 PCI Fast Ethernet”.
- 5 Click the Properties button.
- 6 Remove the checkmark from the option “Disable in this hardware profile.”
- 7 Click OK.
- 8 Close the Control Panel window.

*Topic: How do I install a printer?*

 Always check the printer manufacturer's website for the latest drivers for Windows Me™ before proceeding. Some printers do not function properly without updated drivers for Windows Me.

 If the printer has a USB connection, do not follow the steps below. Contact the manufacturer of your printer for updates or other information that will resolve the problem.

- 1 From the Start menu, select Settings > Printers.
- 2 Click Add Printer.
- 3 Click Next.
- 4 Select Local Printer and click Next.
- 5 Select the appropriate manufacturer and model and click Next.

 If the printer is not included in the list and the printer manufacturer included a disk with a Windows Me Printer driver, choose Have Disk, enter the appropriate path for the disk or CD and click OK.

If the printer is not included on the list and no drivers are included with the printer, choose a driver for a printer that the printer emulates (acts like). Refer to the manual that came with your printer for specific emulation information.

- 6 Select the appropriate port, and then click Next.

- 7 Click Yes to have Windows-based programs use this as the default printer.
- 8 Click Next.
- 9 Click No and then click Finish.

 If prompted for a path to the windows files, use C:\Windows\Options\Cabs.

***To Reach Sony***

For Sony PC Support, call 1-888-4SONYPC (1-888-476-6972) or access the Web site at: <http://www.sony.com/pcsupport>.

## Notes on Use

---

### On the Power Source

- ❑ Your computer operates on 100–120 V AC 50/60 Hz only.
- ❑ The total power draw of installed add-on cards must not exceed the specifications for the power supply. Do not overload the system by installing add-on cards that draw excessive current. The system is designed to provide 2 amps (average) of 5V power for each card in the system not to exceed a total of 10 amps. The total from +5V current draw in a fully-loaded system (with all the add-in card slots filled) must not exceed 10 amps. If you add components to the system that draw current from the power supply, the maximum combined +3.3V and +5V output must not exceed 70 watts.
- ❑ Plug all the power cords for your computer and its peripheral equipment into the same AC supply line. AC derived from different supply lines may result in voltage differences that can cause unstable operation or unwanted weak currents at the time of connection.
- ❑ Do not share the AC outlet with any other power-consuming equipment, such as copying machines or shredders.
- ❑ You can purchase a power strip with a surge protector. This device prevents damage to your computer caused by sudden power surges such as those that may occur during an electrical storm.
- ❑ If you live in an area that experiences frequent power fluctuations, you may want to purchase a UPS (Uninterrupted Power Supply). This device contains both a surge protector and a battery backup. The surge protector prevents damage to your computer caused by power surges. The battery backup safeguards your data during a brief period of power loss.
- ❑ The power control button on the front panel does not turn off the system AC power. To remove power from the system, you must shut down the computer as described in the User Guide and then unplug the AC power cord from the wall outlet or power strip.
- ❑ Do not place heavy objects on the power cord.
- ❑ Do not operate the system with the cover removed. Always reinstall the cover before turning on the system.
- ❑ To disconnect the cord, pull it out by the plug. Never pull the cord itself.

- ❑ Unplug your computer from the wall outlet if you will not be using the computer for a long time.
- ❑ Before touching anything inside the computer, turn the system off and let it cool for ten minutes. This will ensure that the processor heat sink will not be hot.
- ❑ Do not attempt to open the power supply. There are no user-serviceable parts in the power supply. To avoid personal injury or damage to your equipment, refer the repair or replacement of the power supply to qualified personnel only.

### ***On Disposal of the Lithium Battery***

Dispose of the lithium battery properly. In some areas, the disposal of lithium batteries in household or business trash may be prohibited. You can return your unwanted lithium batteries to your nearest Sony Service Center or Factory Service Center. For the Sony Service Center nearest you, call 1-888-4SONY-PC (1-888-476-6972).



**Do not handle damaged or leaking lithium batteries.**

**The lithium battery may explode if mistreated. Do not disassemble it or dispose of it in fire.**

**Replace the battery with a Sony CR2032 lithium battery. Using any battery other than a CR2032 may present a risk of fire or explosion.**

### ***On Handling the Computer System***

- ❑ Do not place your Sony computer in a location subject to:
  - ❑ Heat sources, such as radiators or air ducts
  - ❑ Direct sunlight
  - ❑ Excessive dust
  - ❑ Mechanical vibration or shock
  - ❑ Strong magnets or speakers that are not magnetically shielded
  - ❑ Ambient temperature of more than 95°F (35°C) or less than 50°F (10°C)
  - ❑ High humidity, moisture, or rain
- ❑ Do not place electronic equipment near your computer. The computer's electromagnetic field may cause a malfunction.

- ❑ Provide adequate air circulation to prevent internal heat build-up. Attach the stand to your system to prevent overheating. Do not place your computer on loose surfaces (such as rugs or blankets) or near materials (such as curtains or draperies) that may block its ventilation slots. Leave a space of at least 8 inches from the back panel of your computer. Overheating of your computer may permanently damage your system.
- ❑ Clean your computer's cabinet with a soft, dry cloth or a soft cloth lightly moistened with a mild detergent solution. Do not use any type of abrasive pad, scouring powder, or solvent such as alcohol or benzine, as it may damage the finish of your Sony computer.
- ❑ Should any solid object or liquid fall into the cabinet, keyboard, or mouse, shut down your computer and then unplug it. You may want to have the computer checked by qualified personnel before operating it any further.
- ❑ The computer uses high-frequency radio signals and may cause interference to radio or TV reception. Should this occur, relocate the computer a suitable distance away from the set.
- ❑ Use only specified peripheral equipment and interface cables; otherwise, problems may result.
- ❑ Do not use cut or damaged connection cables.
- ❑ Always switch the power off before connecting your computer to peripheral equipment; otherwise, damage may occur to the integrated circuits in your computer.
- ❑ Your computer, keyboard, and mouse consist of high-precision electronic parts. Do not drop them or bump them against other objects.
- ❑ Your Sony computer will not work with party lines, cannot be connected to a coin-operated telephone, and may not work with multiple phone lines or a private branch exchange (PBX).
- ❑ If the telephone company makes a service call to your home or office and determines that your computer is responsible for the problem, the telephone company may bill you for the service call. Also, if you do not disconnect your computer when it is adversely affecting the telephone line, the telephone company has the right to disconnect your service until you correct the problem.

### ***On Moisture Condensation***

If your computer is brought directly from a cold location to a warm one, moisture may condense inside your computer. In this case, allow at least an hour before turning on your computer. If any problem occurs, unplug your computer, and contact your Sony Service Center.

### ***On Upgrading the System***

- ❑ The procedures described in the online manual, “Upgrading and Maintaining Your Slimtop™ LCD Computer” assume familiarity with the general terminology associated with personal computers and with the safety practices and regulatory compliance required for using and modifying electronic equipment.
- ❑ Disconnect the system from its power source and from any networks, modems, or telecommunications links before you open the system or follow any of the procedures described in the online manual, “Upgrading and Maintaining Your Slimtop™ LCD Computer” . Failure to do so may result in personal injury or equipment damage.
- ❑ Electrostatic discharge (ESD) can damage disk drives, add-in cards, and other components. Follow the procedures described in the online manual, “Upgrading and Maintaining Your Slimtop™ LCD Computer” , only at an ESD workstation. If such a station is not available, do not work in a carpeted area, and do not handle materials that produce or hold static electricity (cellophane wrappers, for example). Ground yourself by maintaining contact with an unpainted metal portion of the chassis while performing the procedure.
- ❑ When removing a slot cover, be careful not to damage components on the system board or add-in cards. You may need to temporarily remove add-in cards that are next to the slot cover you want to remove.

### ***On Handling the Sony Pen Tablet***

- ❑ Do not leave the Sony Pen Tablet directly facing the sun for a long period of time as it can damage the LCD screen.
- ❑ Do not scratch the LCD screen or exert pressure on it. This may cause damage to the screen or cause a malfunction.

- ❑ Using the computer in low temperature conditions may produce a residual image on the screen. This is not a malfunction. When the computer returns to normal temperature, the screen returns to normal.
- ❑ A residual image may appear on the screen if the same image is displayed for a lengthy period of time. The image disappears after a period of time. You can use a screen saver to prevent residual images.
- ❑ The screen becomes warm during operation. This is normal and does not indicate a malfunction.
- ❑ Your Sony Pen Tablet consists of high-precision electronic parts. Do not drop or bump it against other objects.
- ❑ The Sony Pen Tablet display uses high-frequency radio signals and may cause interference to radio or TV reception. Should this occur, relocate the computer a suitable distance away from the radio or TV.

#### ***On Handling a CRT Display***

- ❑ Do not place the display near a strong magnetic force.
- ❑ Do not block the ventilation slots on the display.

#### ***On Using the Hard Disk Drive***

- ❑ Do not place the computer in a location that is subject to vibration or shock.
- ❑ Do not move the computer during operation.
- ❑ Do not subject the computer to sudden changes in temperature.
- ❑ Do not turn off the power while the computer is accessing the hard disk drive.

#### ***On Handling Diskettes***

- ❑ Do not open the shutter manually and touch the surface of the diskette.
- ❑ Keep diskettes away from magnets.
- ❑ Keep diskettes away from direct sunlight and other heat sources.



### **On Handling CD Media**

- Do not touch the surface of the disc.
- Do not drop or bend the disc.
- Do not use adhesive labels to identify the disc. The label may come off while the disc is in use in the optical drive.

### **On Cleaning CD Media**

- Fingerprints and dust on the surface of a disc may cause read errors. Proper care of the disc is essential to maintain its reliability. Do not use solvents such as benzine, thinner, commercially available cleaners or anti-static spray, as they may cause damage to the disc.
- For normal cleaning, hold the disc by its edge and use a soft cloth to wipe the surface from the center out.
- If the disc is badly soiled, moisten a soft cloth with water, wring it out well, and use it to wipe the surface of the disc from the center out. Wipe off any remaining moisture with a dry soft cloth.

## **For Answers to Your Software Questions**

---

### **Sony Service Center**

For the Sony Service Center nearest you, call 1-888-4SONYPC (1-888-476-6972). This service is free of charge for 90 days after the original date of purchase.

**Acrobat® Reader, Adobe GoLive™, Adobe LiveMotion™,  
Adobe Photoshop® LE, Adobe Premiere® LE  
(Adobe Systems Incorporated)**

|          |  |
|----------|--|
| Web site | <a href="http://www.adobe.com/">http://www.adobe.com/</a>  |
| phone    | 206-675-6126 (fee-based support)                           |
| fax      | 206-628-5737   |
| e-mail   | <a href="mailto:techdocs@adobe.com">techdocs@adobe.com</a> |
| hours    | M - F, 6 AM - 5 PM PT                                      |

**America Online® (America Online)**

---

|          |   |
|----------|---|
| Web site | <a href="http://www.aol.com/">http://www.aol.com/</a> |
| phone    | 800-827-6364  |
| hours    | 7 days a week, 24 hours a day                         |

---

**CompuServe® 2000 (CompuServe Interactive Services)**

---

|          |   |
|----------|---|
| Web site | <a href="http://www.compuserve.com/">http://www.compuserve.com/</a> |
| phone    | 800-848-8990  |
| hours    | M - F, 8 AM - 1 AM, Sat - Sun, 10 AM - 10 PM                        |

---

**DirectCD, Easy CD Creator™ (Adaptec, Inc.)**

---

|          |   |
|----------|---|
| Web site | <a href="http://www.adaptec.com">http://www.adaptec.com</a> |
| phone    | 408-945-8600  |
| hours    | M - F, 8AM - 5 PM PT  |

---

**EarthLink TotalAccess™ (EarthLink Network, Inc.)**

---

|          |   |
|----------|---|
| Web site | <a href="http://help.earthlink.net/techsupport/">http://help.earthlink.net/techsupport/</a> |
| phone    | 800-395-8410  |
| e-mail   | <a href="mailto:support@earthlink.net">support@earthlink.net</a>                            |
| hours    | 7 days a week, 24 hours a day   |

---

**McAfee VirusScan® (Network Associates, Inc.)**

---

|          |   |
|----------|---|
| Web site | <a href="http://support.mcafee.com">http://support.mcafee.com</a> |
| phone    | 408-988-3832  |
| e-mail   | <a href="mailto:cybr@nai.com">cybr@nai.com</a>                    |
| hours    | M - F, 9 AM - 5 PM CT   |

---

**Netscape Communicator® (Netscape Communications, Corp.)**

---

|          |   |
|----------|---|
| Web site | <a href="http://help.netscape.com">http://help.netscape.com</a> |
| phone    | 888-4SONYPC (888-476-6972)*                                     |
| hours    | 7 days a week, 24 hours a day                                   |

---

\* Support from 1-888-4SONYPC is free of charge for 90 days after the original date of purchase.

**PhotoPrinter™ 2000 Pro (ArcSoft, Inc.)**

---

|          |  |
|----------|--|
| Web site | <a href="http://www.arcsoft.com">http://www.arcsoft.com</a><br><a href="http://www.photoisland.com">http://www.photoisland.com</a> |
| phone    | 510-440-9901   |
| e-mail   | <a href="mailto:techsupport@arcsoft.com">techsupport@arcsoft.com</a>   |
| hours    | M - F, 8:30 AM - 5:30 PM PT  |

---

**Quicken® 2001 Basic (Intuit, Inc.)**

---

|          |   |
|----------|---|
| Web site | <a href="http://www.intuit.com/support/">http://www.intuit.com/support/</a> |
| phone    | 900-555-4688  |
| hours    | 7 days a week, 24 hours a day   |

---

**Sony Applications (Sony Electronics, Inc.)**

---

|          |   |
|----------|---|
| Web site | <a href="http://www.sony.com/pcsupport">http://www.sony.com/pcsupport</a> |
| phone    | 888-4SONYPC (888-476-6972)*   |
| hours    | 7 days a week, 24 hours a day   |

---

\* Support from 1-888-4SONYPC is free of charge for 90 days after the original date of purchase.

**Sound Forge® XP (Sonic Foundry)**

---

|          |   |
|----------|---|
| Web site | <a href="http://www.sonicfoundry.com/support">http://www.sonicfoundry.com/support</a> |
| phone    | 608-256-5555  |
| fax      | 608-256-7300  |
| e-mail   | <a href="mailto:support@sonicfoundry.com">support@sonicfoundry.com</a>                |
| hours    | M - F, 8 AM - 7 PM CT   |

---

**Windows® Millennium Edition Operating System, Internet Explorer, Outlook® Express, Word 2000 (Microsoft Corporation)**

---

|          |   |
|----------|---|
| Web site | <a href="http://www.sony.com/pcsupport">http://www.sony.com/pcsupport</a> |
| phone    | 888-4SONYPC (888-476-6972)*   |
| hours    | 7 days a week, 24 hours a day   |

---

\* Support from 1-888-4SONYPC is free of charge for 90 days after the original date of purchase.

## Resources

---

Sony provides several support options for your Sony computer. When you have questions about your computer and the preinstalled software, check these sources for answers, in the following sequence:

|  |  |
|--|--|
| <b>Quick Start</b>   | Contains information on how to set up your computer quickly and easily.  |
| <b>VAIO Slimtop™ LCD Computer User Guide</b>                                       | The User Guide contains information on your system's specifications, features and provides solutions to common problems.   |
| <b>Online (Electronic) Documentation</b>   | The User Guide is available electronically on your hard drive. Two additional guides, "Upgrading and Maintaining Your Slimtop™ LCD Computer" and the "Troubleshooting" Help are also available online. To access online documentation, click the Start button, point to Help Center, and then point to the desired document.   |
| <b>Manuals and online help files that may accompany your preinstalled software</b> | Most manuals for preinstalled software are located on your hard disk drive as online help files. You can access online help files from the Help menu in a specific application. A printed manual is available for some applications.   |
| <b>VAIO Support Agent</b>  | VAIO Support Agent can be accessed from the Windows desktop. Using advanced diagnostic technology, Sony's VAIO Support Agent runs scheduled protections of your applications, network settings, and other important software settings. When your software is protected, you can use VAIO Support Agent to repair software problems by restoring your software to any of the previously protected states. |
| <b>Knowledge Database</b>  | Provides instant access to information on commonly encountered problems. Enter a description of your problem and the Knowledge Database searches for the corresponding solutions online. You can access the Sony Knowledge Database at <a href="http://www.sony.com/pcsupport">http://www.sony.com/pcsupport</a>   |

---

---

|  |   |
|--|---|
| <b><i>Sony Fax-on-Demand</i></b>           | This service provides you with answers to commonly asked questions. You can use this automated service to request a list of available topics and then select the topics that you want to receive. To contact the Sony fax-on-demand service, call 1-888-4SONYPC (1-888-476-6972). (Requires a fax machine or fax software.) |
| <b><i>Software Updates</i></b>             | You can download the latest software updates and software patches for your Sony computer by selecting Software Updates on the Sony PC Support web page at <a href="http://www.sony.com/pcsupport">http://www.sony.com/pcsupport</a>   |
| <b><i>VAIO System Reference Manual</i></b> | Provides detailed technical information about your computer's hardware. This document is available from Sony's website at <a href="http://www.sony.com/pcsupport">http://www.sony.com/pcsupport</a>   |

---



# Specifications

|  |   |
|--|---|
| <b>Model</b>   | <b>PCV-LX900</b>  |
| <b>Processor</b>   | 1B GHz <sup>†</sup> Intel® Pentium® III   |
| <b>Hard Disk Drive<br/>C / D Partition</b>               | 40 GB ATA-66<br>C = 16GB / D = 24GB   |
| <b>Standard SDRAM</b>                                    | 128 <sup>†</sup> MB PC-133 SDRAM, expandable to 512MB   |
| <b>Video RAM</b>   | Shared with system memory   |
| <b>Graphics</b>  | SiS 630 graphics hardware acceleration  |
| <b>Sound Capabilities</b>                                | SiS 630 (AC97 Compliance)   |
| <b>CD-RW Drive</b>                                       | 32X max. CD-ROM reading,<br>8X max. CD-R writing,<br>32X max. CD-R reading,<br>4X max. CD-RW writing,<br>20X max. CD-RW reading <sup>‡</sup>  |
| <b>Modem</b>   | Lucent 1648 technology/V.90 compatible data/fax modem<br>(REN 0.7) <sup>**</sup>  |
| <b>Expansion<br/>Capabilities</b>                        | PCI slots (2)   |
| <b>Connection<br/>Capabilities<br/>(Front)</b>           | PC card slot (Card bus support)<br>USB port<br>Memory Stick® media slot<br>i.LINK® (4-pin) port   |
| <b>Connection<br/>Capabilities (Rear)</b>                | USB ports (3)<br>Modem line jack (RJ-11)<br>Phone line jack (RJ-11)<br>CRT display<br>Sony Pen Tablet display<br>Line In jack<br>i.LINK (6-pin) port<br>10Base-T/100Base-TX Fast Ethernet LAN jack (RJ-45)<br>Headphone jack<br>Microphone jack |
| <b>Connection<br/>Capabilities<br/>(Sony Pen Tablet)</b> | PS/2® mouse port<br>PS/2® keyboard port<br>USB port   |

|                              |  |
|------------------------------|--|
| <b>Model</b>                 | <b>PCV-LX900</b>   |
| <b>Supplied Accessories</b>  | Sony Pen Tablet Display (TA-15A)<br>Wheel Mouse<br>VAIO Convertible Keyboard and palmrest<br>VAIO Pen and pen stand<br>Pen tip replacements (5)<br>Pen tip removing tool<br>Power cord<br>Modem cable                              |
| <b>Service</b>               | 90-day limited service. See Warranty Card.††   |
| <b>Limited Warranty</b>      | 90-day parts/labor standard. See Warranty Card.††  |
| <b>Power Requirements</b>    | 230 watts maximum  |
| <b>Power Rating</b>          | AC120V 3A 60Hz   |
| <b>Dimensions</b>            | CPU: 4.2" (w) x 14.5" (h) x 11" (d)<br>(107 mm x 370 mm x 280 mm)<br>Keyboard with palmrest: 17.1" (w) x 2" (h) x 8" (d)<br>(435 mm x 51 mm x 205 mm)<br>LCD display: 17.1" (w) x 14" (h) x 6.4" (d)<br>(435 mm x 357 mm x 163 mm) |
| <b>Weight</b>                | CPU: 14.5 lbs. (6.6 kg)<br>Display: 12.1 lbs. (5.5 kg)<br>Keyboard: 2.2 lbs. (1.0 kg)  |
| <b>Operating Temperature</b> | 50° F to 95° F (+10° C to 35° C)   |

\* GHz denotes microprocessor internal clock speed; other factors may affect application performance.

† 128 MB available. 16 MB allocated to video RAM.

‡ The CD-RW/CD-R/CD-ROM data transfer standard 1X rate is 150 kbytes/s.

Data on a CD-RW is read at a variable transfer rate, ranging from 8X at the innermost track to 20X at the outermost track. The average data transfer rate is 14X(2100 kbytes/s).

Data on a CD-R/CD-ROM is read at a variable transfer rate, ranging from 13X at the innermost track to 32X at the outermost track. The average data transfer rate is 22.5X (3375 kbytes/s).

Data on a CD-RW is written at a constant transfer rate of 2x or 4x. Data on a CD-R is written at a constant transfer rate of 1x, 2x, 4x, or 8x depending on the speed you select.

\*\*Maximum speed for faxing is 14.4 kbytes/s. Your modem is capable of downloading at 56 kbytes/s using K56flex technology or V.90. Your phone service, online service, or Internet Service Provider may not support this technology or operate at this speed.

†† Certain restrictions apply.

Specifications are subject to change without notice.



# Index

## A

- AC input port 17
- adding additional hardware
  - precaution 101
- adjusting voltage settings 100
- air circulation 102
- Application Recovery CD 77, 78
- applications
  - launching
    - problems with 91
- AutoAlert™ 41

## B

- battery
  - disposing 101
- brightness control, on LCD 20

## C

- cables 102
- CD tray
  - opening
    - problems with 90
- CD-RW drive 15
- CD-RW drive, troubleshooting 90
- cleaning
  - computer 101
  - mouse 96

## computer

- adjusting voltage settings 100
- cleaning 101
- condensation and 103
- disposing of battery 101
- lithium battery 8
- removing cover 100
- starting
  - problems with 89
- turning off your computer 100
- upgrading 103
- customer assistance
  - support options 108

## D

- digital video camera recorder
  - using 74
- disconnecting power cords 100
- diskettes
  - handling 104
- displaying the taskbar
  - problems with 97
- displays
  - problems with 89
  - setting up 13
- disposal of lithium battery 8

Driver Recovery CD 79  
DVgate software 47  
    using 74

## E

electronic  
    documentation 108  
    equipment 101  
Eraser, on VAIO Pen 22  
ETHERNET port 18

## G

glare 14

## H

handling diskettes 104  
hard disk 104  
    defragmenting 43  
    partition 43  
hardware  
    adding additional  
        precaution 101  
        troubleshooting 89, 96

headphones jack 18

help 108

## I

i.LINK devices, connecting 44  
i.LINK port 16, 18  
Information LED, on LCD 20  
input devices  
    setting up 13  
installing additional hardware  
    precaution 101  
interference 102, 104

## K

keyboard 13  
    troubleshooting 96

## L

launching applications  
    problems with 91

## LCD

    adjusting 21  
    port 18  
    line jack 18  
    lithium battery  
        disposal 8  
        safety precautions 8  
    locations, choosing 13  
    losing power 100  
    lower switch position,  
        on VAIO Pen 22

## M

Media Bar 47  
Memory Stick media  
    slot 16  
    using 31  
microphone jack 18  
microphones  
    troubleshooting 95  
minimizing glare 14  
modem  
    troubleshooting 94  
monitor port 17  
mouse 13  
    cleaning 96  
    troubleshooting 96

---

MovieShaker 47

## O

online

    help 108

    support options 108

opening

    applications

        problems with 91

    CD tray

        problems with 90

OpenMG Jukebox 47

## P

palmrest 13

PC (PCMCIA) card, using 33

PC card slot 16

pen tip

    on VAIO pen 22

    removing tool 19

    replacements 19

phones

    service precautions 102

PictureGear 48

port

    AC input 17

    ETHERNET 18

    i.LINK 16, 18

    LCD 18

    monitor 17

    power cords 100

    precautions 102

    printer 18

    PS/2 keyboard 20

    PS/2 mouse 20

Universal Serial Bus (USB)

    16, 18, 20

ports

    locating 17

power cords 100

    disconnecting 100

power fluctuations or loss 100

power indicator

    on LCD 20

power source, precautions 100–101

printer port 18

problem solving 89

Programmable Power Keys (PPK), using 37

PS/2 keyboard port 20

PS/2 mouse port 20

## R

radio interference 102, 104

reducing glare 14

removing computer cover 100

rocker switch 22

## S

screens

    reducing glare 14

selecting

    locations 13

setting up your computer

    ergonomic location 13

Smart Capture 48

Sony 19

Sony Fax-on-Demand service 109

Sony Multimedia Computer

Display

problems with 89

Sony Online Support

options 108

speakers

precaution 101

starting your computer

problems with 89

surge protectors 100

system

troubleshooting 89

System Recovery CD 77

**T**

taskbar

problems viewing 97

technical support

support options 108

telephone cable jack 18

telephone jack 18

troubleshooting 89

turning on your computer

problems with 89

TV interference 102, 104

**U**

Universal Serial Bus (USB) port

16, 18, 20

upgrading your computer 103

upper switch position,

on VAIO Pen 22

UPS (Uninterrupted

Power Supply) 100

**V**

VAIO Action Setup 37

VAIO AV Applications 47

VAIO Pen 22

VAIO Support Agent 81

ventilation 13, 102

viewing the taskbar

problems with 97

VisualFlow 48

voltage settings 100

volume control, on LCD 20

**W**

window design 40

Windows taskbar

problems viewing 97

work surfaces 13